



ROBOTIQ POWERPICK10 VACUUM GRIPPER

Original Notice

© 2024 Robotiq Inc.

Robotiq PowerPick10 Vacuum Gripper

LEAN 
ROBOTICS

robotiq.com | leanrobotics.org



Instruction Manual

Table of Contents

Revisions	5
1. General Presentation	7
1.1. Disclaimer	7
1.2. Nomenclature	7
2. Safety	9
2.1. Disclaimer	9
2.2. Risk Assessment	10
2.3. Use of the PowerPick10 Vacuum Gripper	11
3. Installation	13
3.1. Scope of Delivery	13
3.2. Environmental and Operating Conditions	16
3.3. Air Supply	16
3.4. Reception of the Product	17
3.5. Mechanical Installation	17
3.6. Electrical Installation	30
3.7. Supply Pressure Adjustment	33
3.8. Configuration Steps and Tips	33
4. Software	40
4.1. URCap Package on E-Series	40
4.2. Vacuum Gripper Selection	43
4.3. Vacuum Gripper Toolbar	45
4.4. PowerPick node	45
5. Specifications	49
5.1. Technical dimensions	49
5.2. Mechanical Specifications	57
5.3. Tool Center Point and Center of Mass	58
5.4. Electrical Specifications	60



5.5. Control specifications	61
6. Maintenance	62
6.1. Safety Measures	62
6.2. Maintenance	63
7. Spare Parts, Kits and Accessories	65
8. Troubleshooting	69
9. Warranty	70
9.1. Conditions	70
9.2. Warranty Void and Exclusions	71
10. Harmonized Standards	72
11. Appendix	73
12. Contact	74



Revisions

Robotiq may modify this product without notice, when necessary, due to product improvements, modifications or changes in specifications. If such modification is made, the manual will also be revised, see revision information. See the latest version of this manual online at: support.robotiq.com.

2024/11/05

Updated user manual for the release of PowerPick10 Single Cup

2024/04/11

Updated software section to include the URCap.

2024/02/08

Updated user manual to reflect the latest hardware release of the Gripper.

2023/08/09

Updated Tool Center Point and Center of Mass section.

2023/01/31

Initial release.



Copyright

© 2024 Robotiq Inc. All rights reserved.

This manual and the product it describes are protected by the Copyright Act of Canada, by laws of other countries, and by international treaties, and therefore may not be reproduced in whole or in part, whether for sale or not, without prior written consent from Robotiq. Under copyright law, copying includes translation into another language or format.

Information provided by Robotiq in this document is believed to be accurate and reliable. However, no responsibility is assumed by Robotiq for its use. There may be some differences between the manual and the product if the product has been modified after the edition date.

The information contained in this document is subject to change without notice.



1. General Presentation

1.1. Disclaimer

The terms *Gripper*, *PowerPick10 Gripper*, *PowerPick10 Vacuum Gripper* and *PowerPick10* used in the following manual all refer to the Robotiq *PowerPick10 Vacuum Gripper*. The Robotiq *PowerPick10 Vacuum Gripper* is a robotic device designed for industrial applications. The vacuum is generated with a venturi system that uses compressed air as an energy source. It is an end-of-arm tool designed to pick, place and handle a range of items (cardboard boxes as well as non-porous materials) of varying sizes and weights.



NOTICE

The following section presents the key features of the Robotiq PowerPick10 Vacuum Gripper and must not be considered as exhaustive and comprehensive for the operation of the Gripper. Each feature is detailed in the appropriate section.

1.2. Nomenclature

1.2.1. PowerPick10 Gripper

The PowerPick10 Gripper is a mechanical assembly equipped with interchangeable components. It is the end effector of the robot. It uses the negative pressure generated by the PowerPick10 Vacuum Generation Unit to create a vacuum and, through the multiple suction cups, lifts, holds and moves boxes and other objects weighing up to 11.3 kg (24.9 lb) for the Standard Gripper, and 6.5 kg (14.3 lb) for the Single Cup Gripper. To simplify this manual, the word "box" will be used to represent the item to be handled with the Gripper. The PowerPick10 Gripper is directly installed on the wrist of the robot, without a coupling interface.



Fig. 1-1: PowerPick10 Standard Gripper Gripper, Default Configuration





Fig. 1-2: PowerPick10 Single Cup Gripper, Default Configuration

1.2.2. PowerPick10 Vacuum Generator



The PowerPick10 Vacuum Generator is a dual-channel electrical and pneumatic device composed of two solenoid valves, two pressure sensors and two vacuum generator cartridges. It is an intermediate control device, connected to the robot control box and the PowerPick10 Gripper via I/O terminal blocks and air tubes. The PowerPick10 Vacuum Generator creates and releases the vacuum for the PowerPick10 Gripper.



Fig. 1-3: PowerPick10 Vacuum Generator

2. Safety

2.1. Disclaimer

	 CAUTION
	<p>Any user of the Robotiq PowerPick10 must have read and understood all of the instructions in the following section before operating it.</p> <p>It is the installer/operator's responsibility to ensure that all local safety measures and regulations are met.</p>

The intent of this section is to provide general guidelines for safe use of the PowerPick10 Vacuum Gripper.

Always follow local rules and regulations.

The installer is responsible for the safe installation and commissioning of the PowerPick10 Vacuum Gripper.

Robotiq accepts no liability for damage, injury or any legal responsibility incurred directly or indirectly from the use of this product.



The user (installer and operator) shall observe safe and lawful practices including but not limited to those set forth in this document.

The term *operator* refers to anyone responsible for any of the following operations on the Robotiq Vacuum Gripper:

- Installation
- Control
- Maintenance
- Inspection
- Calibration
- Programming
- Decommissioning

This manual covers the various components of the PowerPick10 Vacuum Gripper and the general operations regarding the whole life-cycle of the product, from installation to operation and decommissioning.

The drawings and photos in this manual are representative examples. However, discrepancies may be observed between the visual supports and the actual product.

	 WARNING
	<p>Any use of the PowerPick10 Vacuum Gripper in non-compliance with these instructions is deemed inappropriate and may cause injury or damage.</p>



2.2. Risk Assessment

2.2.1. General Risk Assessment

The robot, the Gripper and any other equipment used in the final application must go through a comprehensive risk assessment process before they can be used.



The following non-exhaustive list presents risks that must be assessed during the integration process:

- Risk of contact between body parts and the Gripper and/or suction cups;
- Risk of load ejection resulting from loss of vacuum;
- Risk of load dropping resulting from loss of vacuum;
- Risk of load ejection resulting from loosened fasteners on the end effector;
- Risk of pinching between the Gripper and the items being handled, or other objects in the environment;
- Risk of injury resulting from misuse of the product;
- Risk of entanglement of the tool cables resulting from inappropriate robot cable management.



Depending on the application, configuration and items being handled, additional hazards may be present. For instance, the boxes handled by the Gripper could be inherently dangerous to the operator. Such hazards may require additional protection or safety measures (e.g., light curtains, safety scanners, enclosure, etc.).

To ensure an adequate level of safety, floor markings must be applied to delineate safe zones around the work cell. It is the responsibility of the integrator to establish the proper safe distance from the work cell to protect the user.

The software allows for the limiting of the robot's speed, force and working area in order to reduce residual risk. These measures can namely give the operator more time to react appropriately, and reduce the robot's brake time.

	 <p style="text-align: center;">WARNING</p>
	<p>Collisions between a person and the PowerPick10 Gripper may result in material damage, bodily injury and even death. Anyone in the vicinity of the work cell should take the necessary precautions.</p> <ul style="list-style-type: none"> • Make sure no individual or asset are in the vicinity of the robot and/or Gripper prior to initializing the robot. • Always keep body parts and clothing away from the Gripper while the device is powered on. • Do not use the Gripper on people or animals. • Never stand under suspended loads held by the Gripper. • Secure the Gripper properly before operating the robot. • Always meet the Gripper payload specifications.





	 WARNING
	<p>Maintenance and repair work on electrical equipment must only be carried out by qualified and authorized personnel.</p> <ul style="list-style-type: none"> • Never supply the PowerPick10 Vacuum Generator with power from an alternating current source. • Make sure that the PowerPick10 Generator I/O cable is always secured at both ends. • Always meet the recommended keying for electrical connections.

2.2.2. Noise Level

At the optimal pressure (please refer to the **Specifications** section), the noise level at the workstation is 76 dBA. Hearing protection is recommended but not mandatory. Make sure that all local safety measures and regulations are met.



2.2.3. Pneumatic Limitations

- The maximum permissible pressure of all pneumatic components must never be exceeded (8 bar).
- Pneumatic tubing must be inspected at regular intervals and, if necessary, replaced (please refer to the **Maintenance** section for more details).
- Leaky connections must be sealed to avoid breakage, unnecessary or excessive noise, loss of energy, etc.
- Loss of vacuum can occur due to power failure or air supply interruption.

	 WARNING
	<ul style="list-style-type: none"> • Make sure that the air tubes are properly secured before pressurizing the PowerPick10 Gripper. • Make sure that the air tubes are not pressurized before removing the air supply tube or any other air tube from the PowerPick10 Vacuum Generator and Gripper. • Never operate the PowerPick10 Gripper with leaking or worn parts.

2.3. Use of the PowerPick10 Vacuum Gripper

The PowerPick10 Vacuum Gripper is designed to pick, place and handle cardboard boxes or other non-porous items. If the Gripper is used for other applications, make sure to consider the type of item to be handled in the risk assessment (please refer to the **General Risk Assessment** section) and take the appropriate safety measures.

	 CAUTION
	The Gripper is NOT intended for applying force against objects or surfaces.



- Only use the Gripper in its original condition without unauthorized modifications.
- Only use the Gripper if it is in perfect technical condition.
- Follow all safety rules and regulations of the workplace when installing, operating and performing maintenance work on the Gripper.
- Wear all recommended personal protective equipment in accordance with the safety standards of the workplace, including but not limited to safety glasses, hearing protection, safety footwear, head protection.
- Handle with care any tool that contains sharp edges, pinching surfaces or generate heat.
- Comply with local, state, province and/or federal laws, regulations and directives regarding automation safety and general machine safety.

The unit should be used exclusively within the range of its technical data. Any other use of the product is deemed improper and unintended. Robotiq will not be liable for any damages resulting from any improper or unintended use

When manually moving the Gripper installed on the robot (e.g., for teaching, maintenance, inspection purposes) make sure not to insert fingers through bracket cut outs and openings.

Make sure that all workers who operate the Gripper have received the appropriate training to do so in a safe manner.

Perform all necessary maintenance work periodically as specified in the [Maintenance section](#).



3. Installation

This section will guide the user through the installation and general setup of the Robotiq PowerPick10 Vacuum Gripper.

Before installing:

- Read and understand the safety instructions related to the PowerPick10 Vacuum Gripper. Please refer to the [Safety section](#) for more information.
- Verify the package according to the scope of delivery and the order.
- Make sure to have the required parts, equipment and tools listed in the scope of delivery.
- Make sure to meet the recommended environmental conditions.



NOTICE

This manual uses the metric system. Unless specified, **all dimensions are in millimeters.**



WARNING

When installing:

- Do not operate the PowerPick10 Vacuum Gripper or even turn on the power supply before confirming the device is firmly attached and the work area is clear.
- Make sure that the air supply source is secured.
- Failure to properly secure and install the equipment can result in material damage and bodily injury.

If the installation is not performed in compliance with the manufacturer's instructions, the warranty will be void.

3.1. Scope of Delivery

3.1.1. PowerPick10 Standard Vacuum Gripper Kit

- 1 x PowerPick10 standard kit:
 - 1 x PowerPick10 Vacuum Generation Unit
 - 1 x Vacuum Generator
 - 1 x Mounting bracket
 - 1 x Filter-regulator with shut-off valve
- 1 x M12-12 pin I/O cable (3 m)
 - 1 x 2 in pre-perforated grommet



- 1 x PowerPick10 Standard Vacuum Gripper, pre-assembled, default configuration:
 - 1 x Manifold assembly
 - 1 x 200 mm hollow offset link
 - 2 x Small suction cup brackets
 - 4 x 75 mm suction cups
 - 2 x 8 mm air tubes (250 mm)
 - 2 x 8 mm air tubes (350 mm)
- 1 x PowerPick10 Gripper Offset Accessory kit:
 - 2 x Large suction cup brackets
 - 4 x Additional 8 mm air tubes (400 mm)
 - 1 x 100 mm hollow offset link
 - 1 x 0 mm offset plate
 - 1 x 120 mm wrist extension assembly
- 1 x 10 mm double air tube (3 m)
- 1 x Hardware kit:
 - 4 x M6 x 30 mm hex socket head cap screw with captive spring washer
 - 14 x 190 mm cable ties
 - 1 x Tubing curler
 - 1 x Pneumatic adapter 1/2 BSPP to 12 mm tube (~4 m)
 - 2 x M6 external tooth lock washers
 - 1 x M6 flange nut
- 1 x Installation tool kit:
 - 1 x 5 mm hex key, L-shape
 - 1 x 21 mm / 24 mm double-ended wrench
- 4 x 52 mm suction cups (optional)
- 4 x 78 mm suction cups (optional)

3.1.2. PowerPick10 Single Cup Vacuum Gripper Kit

- 1 x PowerPick10 single cup kit:
 - 1 x PowerPick10 Vacuum Generation Unit
 - 1 x Vacuum Generator
 - 1 x Mounting bracket



- 1 x Filter-regulator with shut-off valve
- 1 x M12-12 pin I/O cable (3 m)
 - 1 x 2 in pre-perforated grommet
- 1 x PowerPick10 Single Cup Vacuum Gripper, pre-assembled, default configuration:
 - 1 x Manifold assembly
 - 1 x Single cup bracket
 - 1 x 75 mm suction cup
 - 2 x 8 mm pneumatic plugs
 - 2 x 8 mm air tubes (160 mm)
- 1 x 10 mm double air tube (3 m)
- 1 x 10 mm double air tube extension (5 m)
- 1 x Hardware kit:
 - 4 x M6 x 30 mm hex socket head cap screw with captive spring washer
 - 14 x 190 mm cable ties
 - 1 x Tubing curler
 - 1 x Pneumatic adapter 1/2 BSPP to 12 mm tube
 - 2 x M6 external tooth lock washers
 - 1 x M6 flange nut
- 1 x Installation tool kit:
 - 1 x 5 mm hex key, L-shape
 - 1 x 21 mm / 24 mm double-ended wrench
- 1 x 52 mm suction cup (**optional**)
- 1 x 90 mm suction cup (**optional**)
- 1 x 100 mm hollow offset link kit (**optional**)
 - 1 x 100 mm hollow offset link
 - 4 x M6 x 15 mm hex socket head cap screws
 - 2 x Strengthening brackets
 - 2 x 8 mm air tubes (300 mm)
- 1 x 200 mm hollow offset link kit (**optional**)
 - 1 x 200 mm hollow offset link
 - 4 x M6 x 15 mm hex socket head cap screws





- 2 x Strengthening brackets
- 2 x 8 mm air tubes (400 mm)
- 1 x 120 mm wrist extension kit (**optional**)
 - 1 x 120 mm wrist extension
 - 4 x M6 x 15 mm hex socket head cap screw with captive spring washer
 - 2 x 8 mm air tubes (200 mm)

3.2. Environmental and Operating Conditions

Condition	Values	
	Min	Max
Operating temperature (Vacuum Generator)	0°C (32°F)	50°C (122°F)
Operating temperature (suction cups)	10°C (50°F)	50°C (122°F)
Storage temperature	-20°C (-4°F)	70°C (158°F)
Humidity (non-condensing)	35% RH	85% RH
IP rating	IP2X	
Dust, soot and water	Affect the time between maintenance	
Food	No	
Clean room		
Intrinsic Safety (IS)		
Corrosive liquids or gases		
Explosive liquids or gases		

Table 3-1: Environmental and operating conditions of the PowerPick10 Gripper

3.3. Air Supply

	 CAUTION
	<ul style="list-style-type: none"> • Use dry and filtered air only. • Follow ISO 8573-1 Class 7.4.4. • The maximum pressure allowed is 8 bar (115 psi). The optimal pressure for compressed air consumption is 6 bar (87 psi). • Robotiq recommends using a local pressure regulator with a filter and air dryer. The filter should prevent any dust particle larger than 5 µm from getting inside the system.



3.3.1. Connecting the Supply Line

Compressed air must be supplied to the Vacuum Gripper according to the technical specifications.

The air supply tubing must be connected and disconnected to or from the inlet port only when the line is depressurized.

It is recommended to use a lockout valve before connecting to the product.

To protect against whipping hazards, the air supply tubing (connected to the PowerPick10 Vacuum Generator) must be firmly secured. An air fuse can also be installed.

At optimal pressure (6 bar / 87 psi), the air supply line must ensure an air flow of 266 lpm.

Make sure any other pneumatic equipment connected to the same supply line is not temporarily reducing the air flow made available for the vacuum generator.

3.3.2. Depressurizing the Supply Line

In order to safely depressurize the supply line, the air supply must first be shut off.

If no lockout valve is present to depressurize the line, the Gripper can be activated until the pressure is fully released.

3.4. Reception of the Product

3.4.1. Visual Inspection

Inspect the package for damage or defects before and after opening it.

Make sure to have all components in hand before discarding the box and packaging material.

If damage or defects are discovered, or if components are missing, contact the Robotiq support team at support@robotiq.com.

3.5. Mechanical Installation



WARNING

Failure to properly secure and install the equipment can result in material damage and bodily injury.

The warranty will not cover material damage resulting from an installation that did not comply with the instructions found in this manual.



3.5.1. PowerPick10 Vacuum Generation Unit Installation

Installation

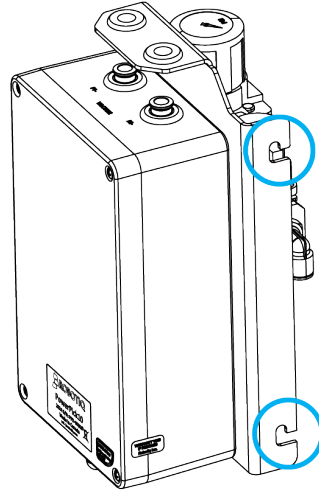





Fig. 3-1: PowerPick10 Vacuum Generation Unit

1. Identify the area where the PowerPick10 Vacuum Generation Unit will be installed. Choose a location so that the electrical cable and air tubes will not obstruct the work environment.
2. Install the Powerpick10 Vacuum Generation Unit using two (2) M8 bolts (tools and hardware not provided).

	 CAUTION
	<p>Make sure the installation of the PowerPick10 vacuum generator on a machine or piece of equipment does not alter the warranty or certification of said machine or piece of equipment.</p>

3. Connect a 12 mm air tube (~4 m) (not provided) to the air supply source and to the PowerPick10 vacuum generator.
4. Connect the PowerPick10 vacuum generator to the robot control box. Please refer to the **Electrical Installation** section for more details.

	NOTICE
	<p>When the PowerPick10 Vacuum Gripper is used in conjunction with either the PE10 Robotiq Palletizing Solution, follow the PowerPick10 Vacuum Generation Unit installation instructions found in the corresponding Palletizer user manual.</p>

3.5.2. PowerPick10 Gripper Installation

Required Tools

Included:

- 1 x 5 mm hex key
- 1 x 21 mm / 24 mm double-ended wrench



Not included:

- Torque wrench
- 10 mm hex key

Overview

PowerPick10 Standard Gripper

Upon receipt, PowerPick10 Standard includes the following components:

- 1 x PowerPick10 Standard Gripper, default configuration, pre-assembled with the following components:
 - 1 x Manifold Assembly
 - 1 x 200 mm hollow offset link
 - 2 x Small suction cup brackets with 75 mm suction cups
 - 2 x 8 mm air tubes (250 mm)
 - 2 x 8 mm air tubes (350 mm)
- 1 x PowerPick10 Vacuum Gripper Accessories
 - 2 x Large suction cup brackets
 - 4 x Additional 8 mm air tubes (400 mm)
 - 1 x 100 mm horizontal offset tube
 - 1 x 0 mm offset plate
 - 1 x 120 mm wrist extension assembly

PowerPick10 Single Cup Gripper

Upon receipt, PowerPick10 Single Cup includes the following components.

- 1 x PowerPick10 Single Cup Gripper, default configuration, pre-assembled with the following components:
 - 1 x Manifold Assembly
 - 1 x Single cup bracket with 75 mm suction cup
 - 2 x 8 mm pneumatic plugs
 - 2 x 8 mm air tubes (160 mm)

The following instructions detail how to install any Gripper configuration. However, use the configuration that corresponds best to the application. For more detail about the possible Gripper configurations, please refer to the **Configuration Steps and Tips** section.



NOTICE

Please use the Robotiq Configurator to simulate the configuration that corresponds best to the application at hand. Should the application require more than one configuration, consider using a gripper arrangement that adapts to every situation.





Fig. 3-2: PowerPick10 Standard Gripper, Default Configuration



Fig. 3-3: PowerPick10 Single Cup Gripper, Default Configuration



CAUTION

Any unused manifold port should be covered with a port plug to avoid air leakage.

Installation of the Manifold on the Gripper

Align the pins on the manifold with the corresponding holes on the wrist extension, hollow offset link or single cup bracket. Please refer to the figures below for correct alignment.

Secure the manifold onto the attached part with one (1) **M6 x 10 mm** hex socket head cap screw using the provided 5 mm hex key. Do not over tighten for it could compress the manifold and apply undesired pressure when installed on the robot arm. To that effect the **maximum torque recommended is 0.5 Nm (0.4 lb-ft)**.



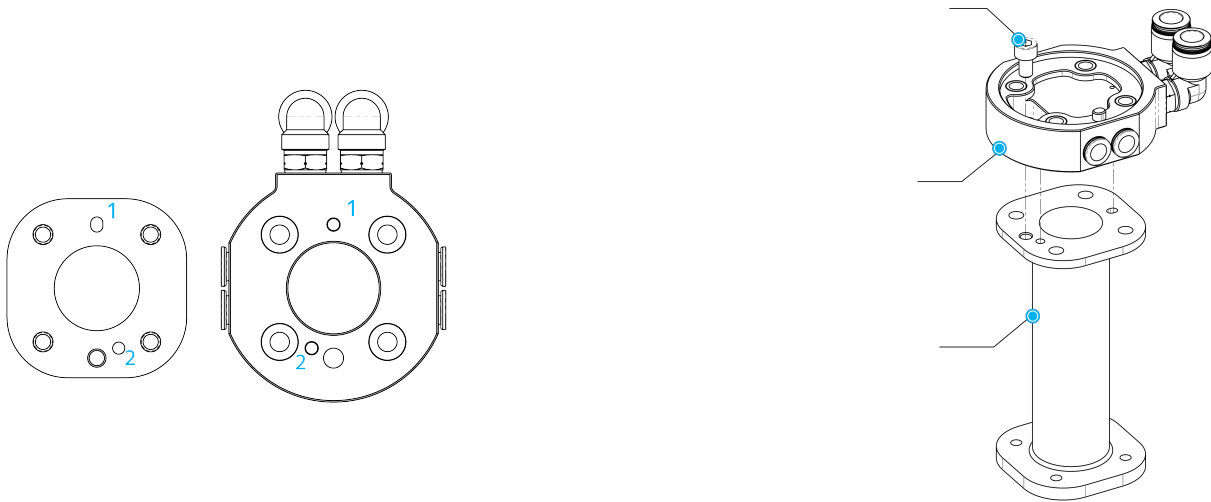

Fig. 3-4: Installation of the Manifold on the Wrist Extension

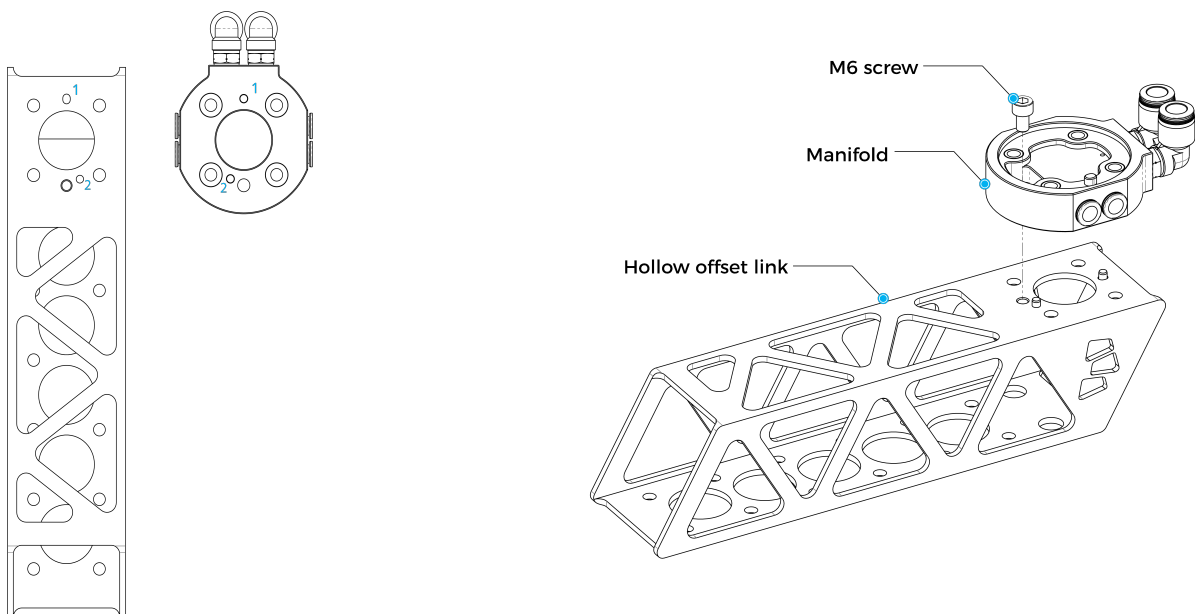

Fig. 3-5: Installation of the Manifold on the Hollow Offset Link



NOTICE

The 200 mm hollow offset link is shown in this figure, but the same steps can be followed to install the manifold on the 100 mm hollow offset link.



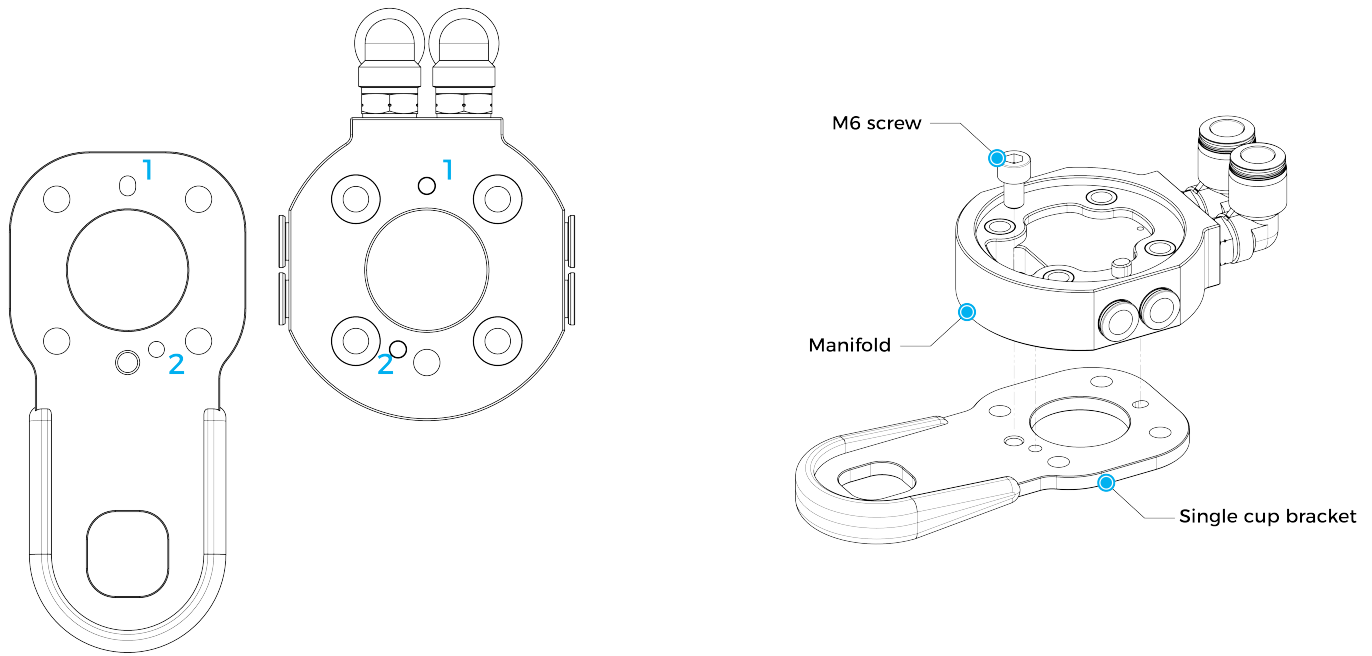

Fig. 3-6: Installation of the Manifold on the Single cup bracket

Installation of Components on the Wrist Extension

Align the pins on the Wrist Extension with the corresponding holes on the hollow offset link, 0 mm offset plate or single cup bracket. Please refer to the figures below for the correct alignment.

Secure the attached part onto the wrist extension with four (4) **M6 x 15 mm** socket head cap screws with captive spring washer using the provided 5 mm hex key. **Required torque is 8 Nm (5.9 lb-ft).**

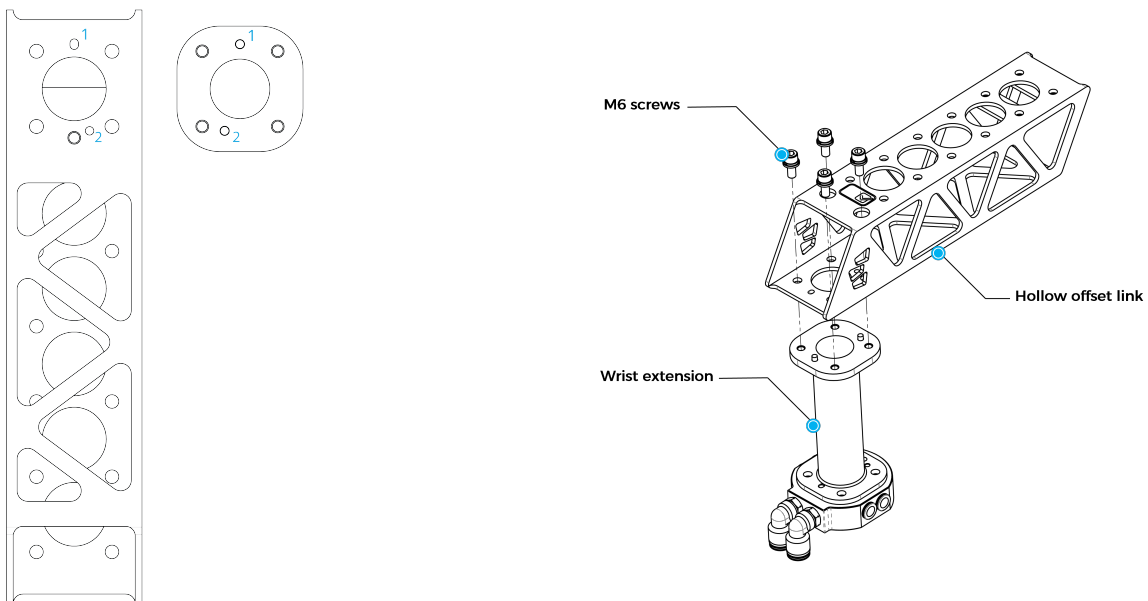

Fig. 3-7: Installation of the Hollow Offset Link on the Wrist Extension



NOTICE

The 200 mm hollow offset link is shown in this figure, but the same steps can be followed to install the manifold on the 100 mm hollow offset link.

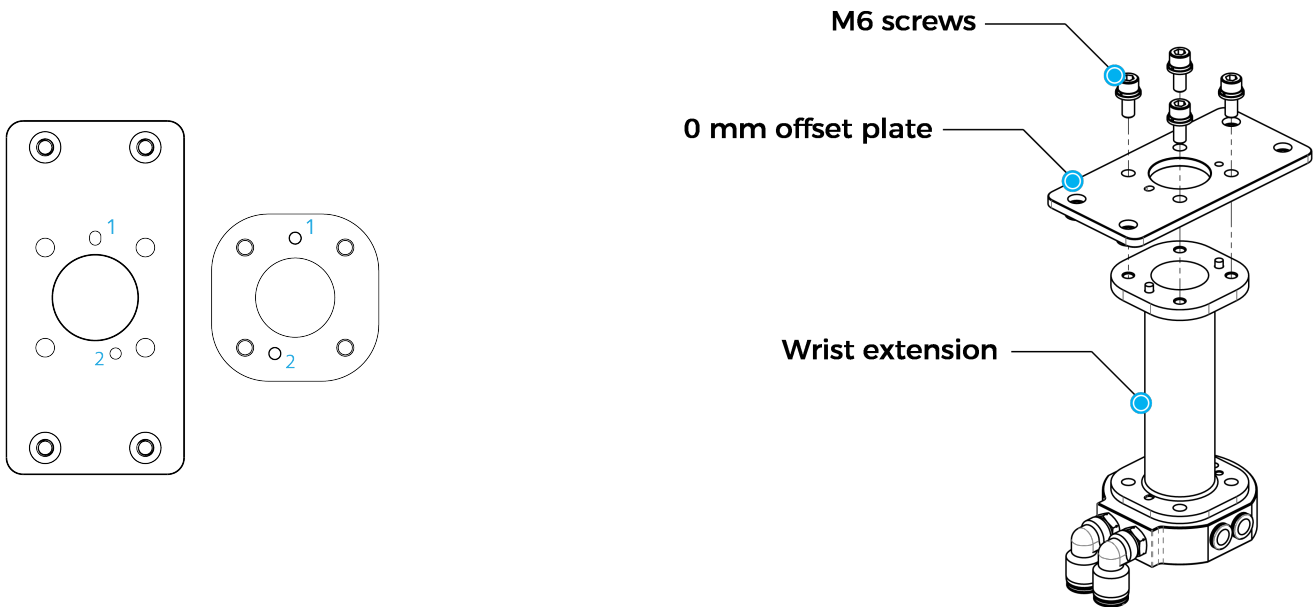

Fig. 3-8: Installation of the 0 mm Offset Plate on the Wrist Extension

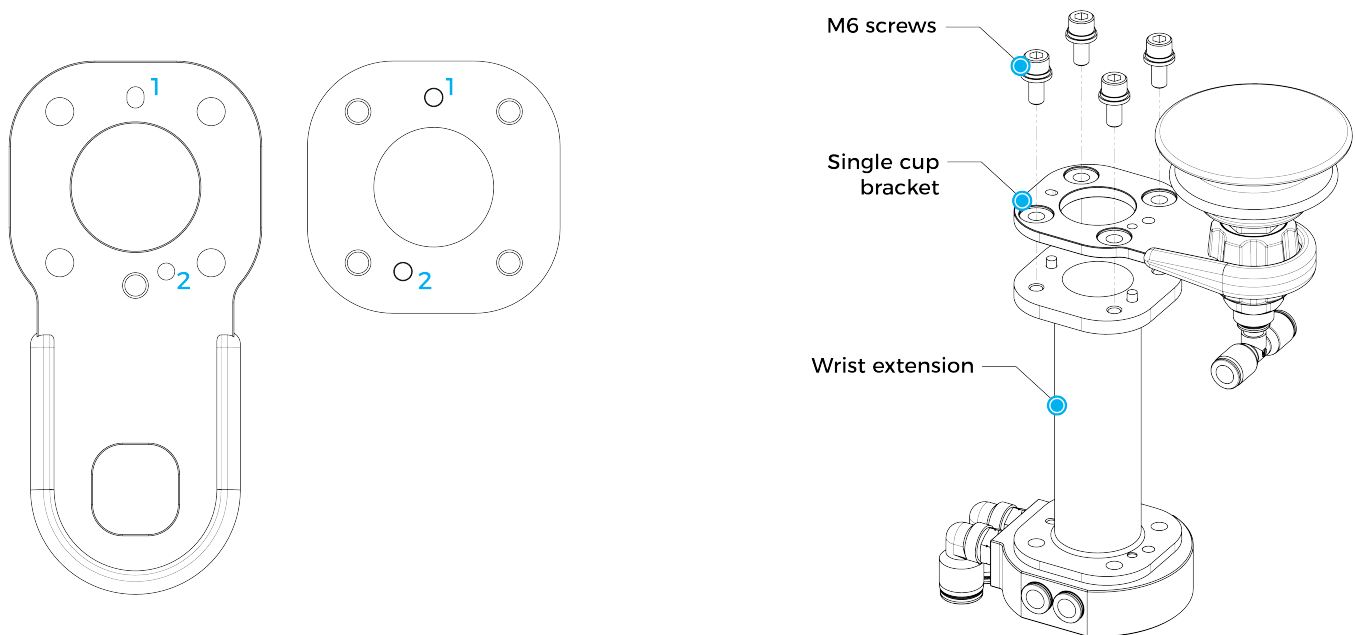

Fig. 3-9: Installation of the Single cup bracket on the Wrist Extension



Installation of Suction Cup Brackets

Suction Cup Brackets on Hollow Offset Link

Install the suction cup brackets under the hollow offset link, in the desired position.

Install the strengthening brackets on the opposite side, inside the hollow offset link. The self-clinching nuts on the strengthening brackets should be facing up.

From underneath the gripper, using the provided 5 mm hex key and four (4) **M6 x 15 mm** hex socket head cap screws, fasten the suction cup brackets and strengthening brackets to the hollow offset link. **Required torque is 9.5 Nm (7.0 lb-ft).**



NOTICE

The 200 mm hollow offset link is shown in this figure, but the same steps can be followed to install suction cup brackets on the 100 mm hollow offset link.

Insert one end of the 8 mm air tube in the manifold and the other end in the elbow fitting of the air node.

Repeat for all air nodes.



NOTICE

If necessary, when using the small brackets or the single cup bracket, cut the tubes to the required length.

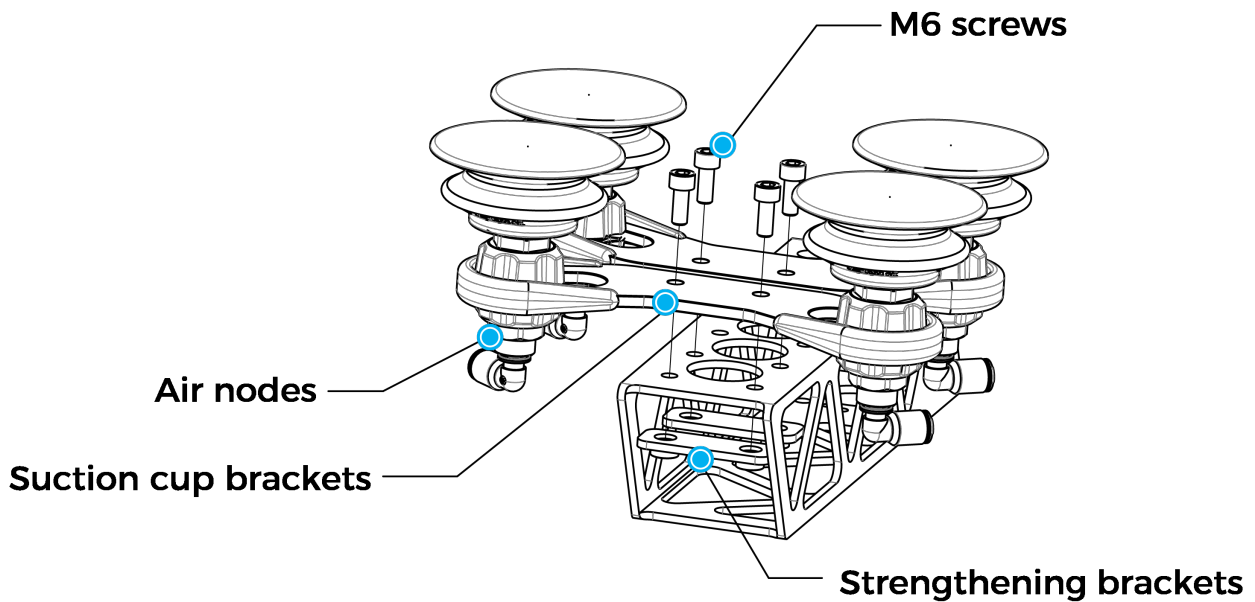

Fig. 3-10: Installation of Suction Cup Brackets on the Hollow Offset Link



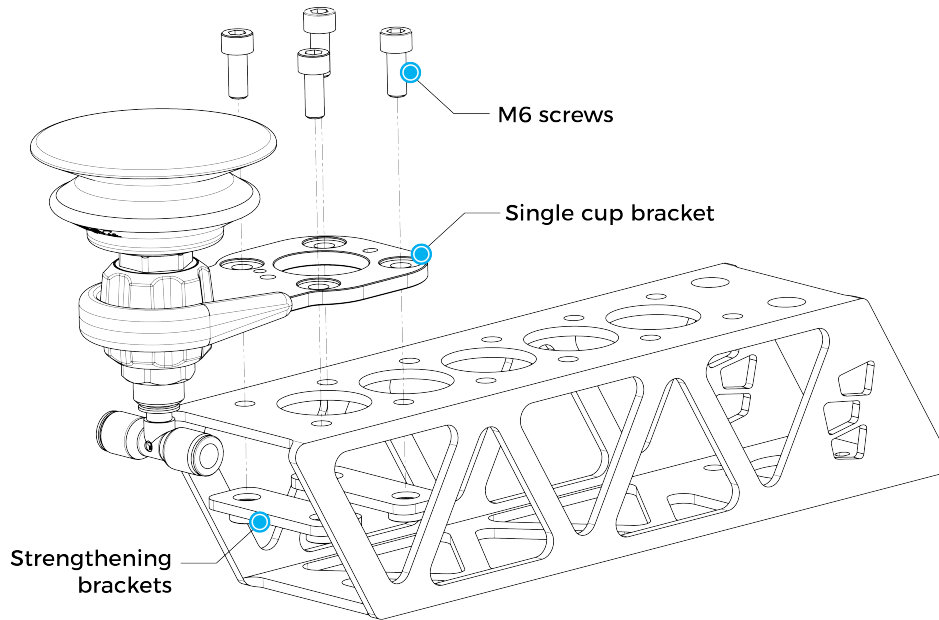

Fig. 3-11: Installation of the Single cup bracket on the Hollow Offset Link

Suction Cup Brackets on 0 mm Offset Plate

Position the suction cup brackets under the 0 mm offset plate, aligned with the self-clinching nuts.

From underneath the gripper, using the provided 5 mm hex key and four (4) **M6 x 15 mm** hex socket head cap screws, fasten the suction cup brackets to the 0 mm offset plate. **Required torque is 9.5 Nm (7.0 lb-ft).**

Insert one end of the 8 mm air tube into the manifold and the other end into the elbow fitting of the air node.

Repeat for all air nodes.



NOTICE

If necessary, when using the small brackets, cut the tubes to the required length.

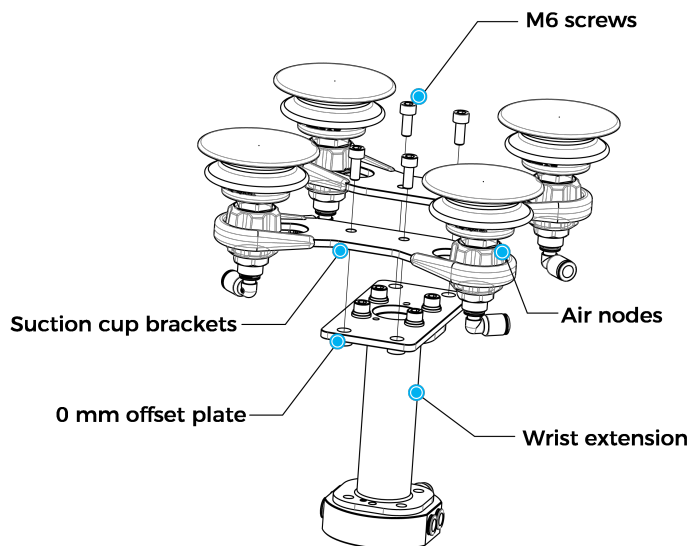

Fig. 3-12: Installation of Suction Cup Brackets on 0 mm Offset Plate



Repositioning Suction Cups

1. Unscrew the air bolts by hand just enough to allow the air nodes to move freely in the openings of the suction cup brackets.
2. Reposition the air nodes as desired along the openings of the suction cup brackets.
3. Tighten the air bolts by hand at the desired location.
 - a. The part of the air bolt that fits in the bracket openings has two flat edges; align the flat edges of the air bolt with the flat edges of the bracket openings.
 - b. Once the air bolts are at the desired location, tighten the air bolts enough so that the air nodes do not move when operating the Gripper. If necessary, use the 21 mm / 24 mm double-ended wrench provided.
 - c. Make sure the air tubes are securely connected to the air nodes and that the suction cups are screwed on tight enough to prevent any leak. If necessary, insert a 10 mm hex key (not provided) at the bottom of the suction cups and tighten them while holding the air bolts with the 21 mm / 24 mm double-ended wrench provided.

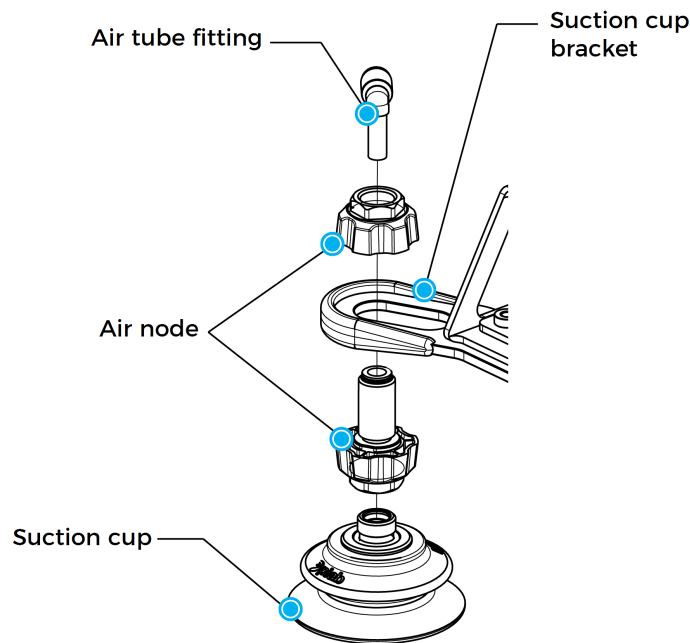

Fig. 3-13: PowerPick10 Air Node Assembly

Replacing or Changing Suction Cups

1. Using a 10 mm hex key (not provided), unscrew the suction cups and remove them from the air nodes. If necessary, use the 21 mm / 24 mm double-ended wrench provided to hold the air bolts.
2. Select suction cups that correspond to the application at hand, and that fit with the 3/8 BSPP (G 3/8) female thread under the air bolt.
3. Using the appropriate tool, install the desired suction cups on the air nodes. Make sure the suction cups are screwed on tight enough to prevent any leak. If necessary, hold the air bolts with the 21 mm / 24 mm double-ended wrench provided.



Changing Suction Cup Brackets

1. Disconnect the elbow fittings from the air nodes.
2. Unscrew the air bolts by hand and remove the air nodes from the suction cup brackets.
3. Remove the M6 socket head cap screws, holding the suction cup brackets to the gripper offset equipment using the provided 5 mm hex key.
4. Remove the suction cup brackets.
5. Install the air nodes on the desired suction cup brackets. Please refer to the **Configuration Steps and Tips** section to select the appropriate brackets.
6. Install the desired suction cup brackets onto the gripper offset equipment with the four (4) M6 socket head cap screws, using the provided 5 mm hex key. **Required torque is 9.5 Nm (7 lb-ft).**
7. Connect the four (4) elbow fittings to the air nodes.

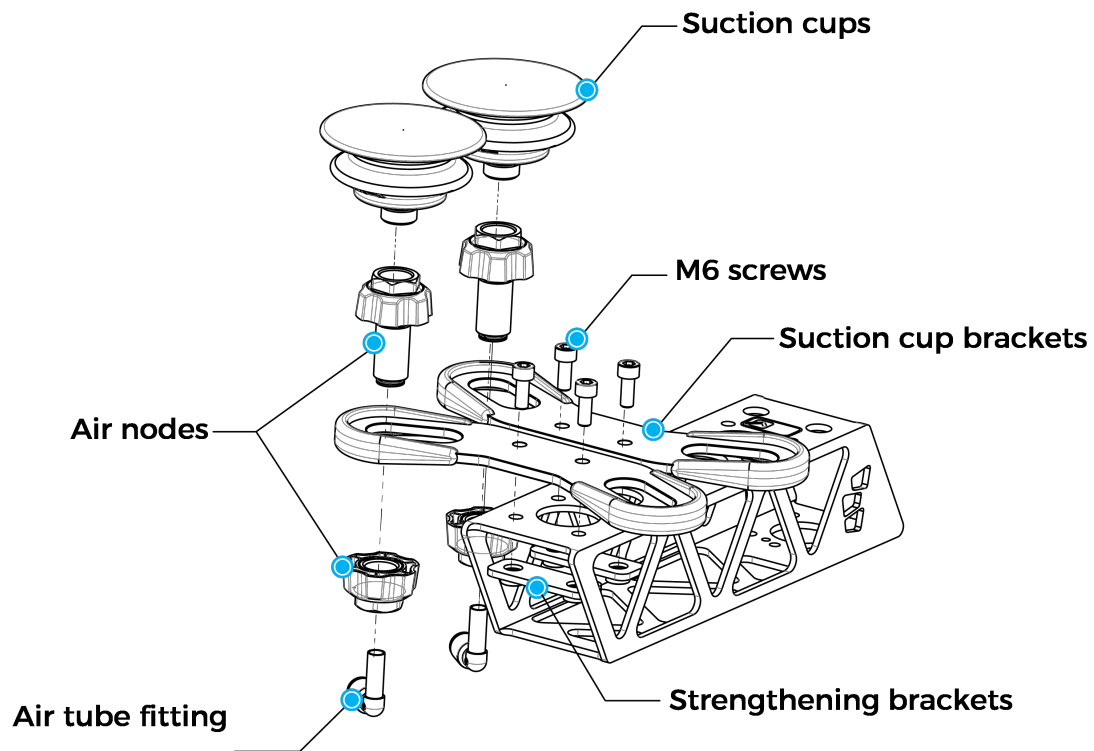
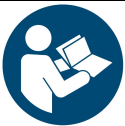

Fig. 3-14: Changing PowerPick10 Suction Cup Brackets



NOTICE

In the figure above, two (2) air nodes have been removed for ease of viewing.



Installation of Gripper Assembly on Robot Wrist

Install the Gripper directly on the robot wrist (no coupling required). Align with the dowel pin on the robot wrist. Please refer to the figures below for the correct alignment.

Secure the Gripper onto the robot wrist with four (4) M6 x 30 mm socket head cap screws with captive spring washer using the provided 5 mm hex key. Required torque is 8 Nm (5.9 lb-ft).

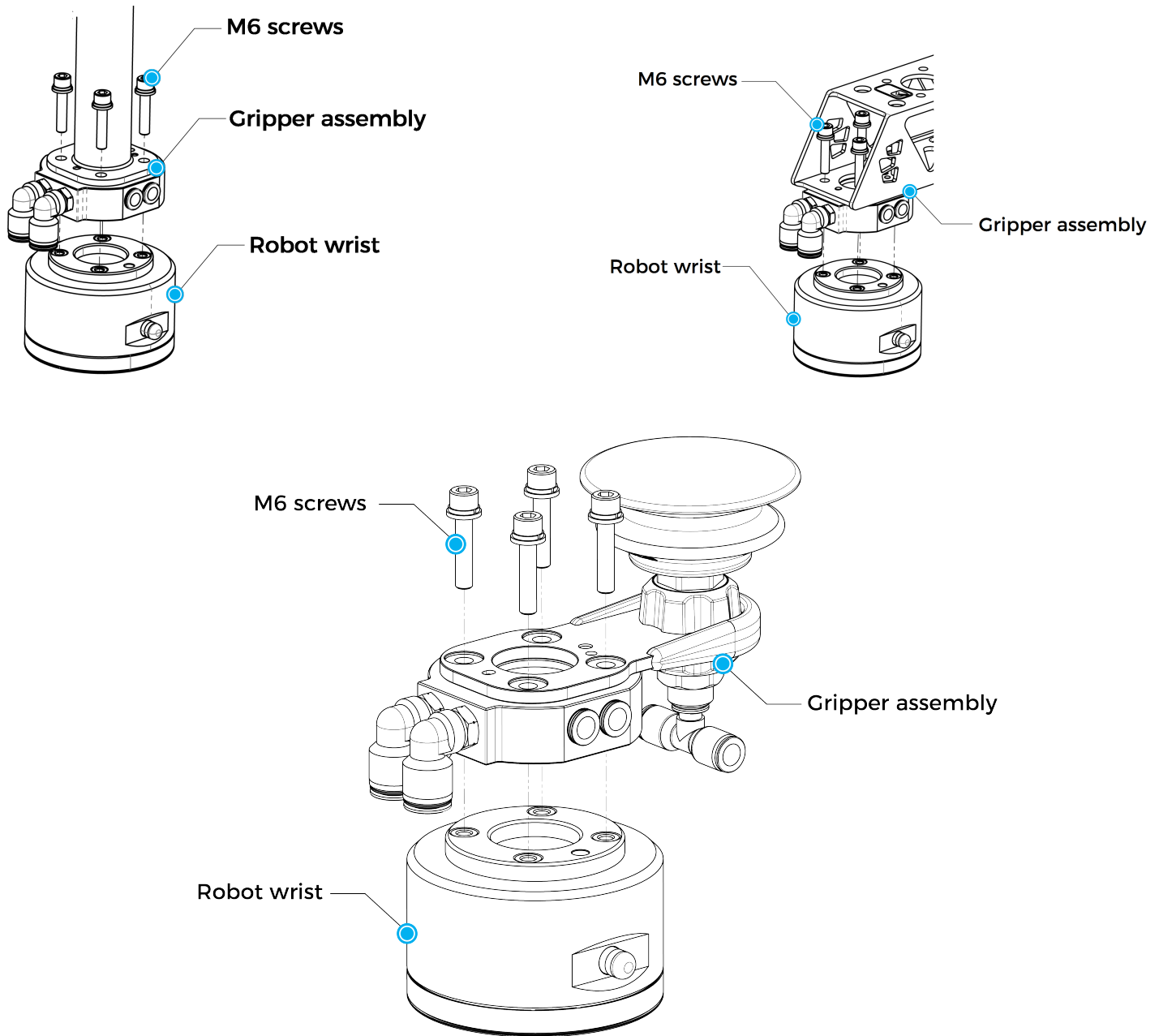

Fig. 3-15: Installation of the Gripper Assembly on the Robot Wrist

3.5.3. Air Tubing

Required Tools

Not included:

- Tube cutter

Routing



NOTICE

Follow cable management good practices: position and secure the air tubes so they do not clutter the working environment. Cut the air tubes to the right length if necessary.

Air Supply to PowerPick10 Vacuum Generation Unit

1. If the supplied 12 mm air tube (~4 m) is long enough, connect the end of the 12 mm air tube to the air filter or air supply (please refer to the **Air Supply** section for more information).
2. Push the air tube until it cannot go any further.
3. If the supplied 12 mm air tube is (~4 m) not long enough, remove the 12 mm air tube from the pneumatic elbow fitting entering the air filter/regulator (see figure below).
4. With the appropriate length of 12 mm air tubing (not supplied), connect one end to the pneumatic elbow fitting entering the air filter/regulator and the other end to the air filter or air supply (please refer to the **Air Supply** section for more information).
5. Push the air tube until it cannot go any further.

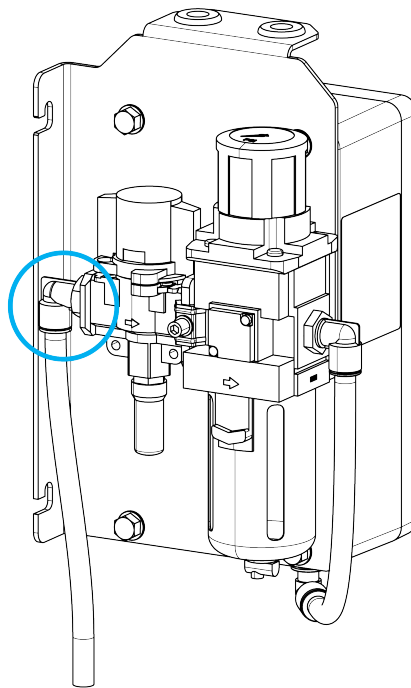

Fig. 3-16: Filter-Regulator Entry Port



PowerPick10 Vacuum Generator to PowerPick10 Gripper

1. Connect the end of the 10 mm double air tube identified as "BASE side" to the fittings identified "P1-" and "P2-" on the PowerPick10 Vacuum Generator.
2. Push the air tube until it cannot go any further.
3. Connect the end of the 10 mm double air tube identified as "TOOL SIDE" to the pneumatic elbow fittings of the PowerPick10 Gripper's manifold at the end of the robot arm.
4. Push the air tube until it cannot go any further.



NOTICE

When the PowerPick10 Vacuum Gripper is used with either the PE10 or AX10 Robotiq Palletizing Solution, please refer to the Cable Management System section found in the corresponding Palletizer user manual.



NOTICE

Make sure the air tube is neither too tight nor too loose so that the robot can move freely, without the air tube getting stuck when moving.

A tube curler and 190 mm cable ties are supplied to help in that matter.

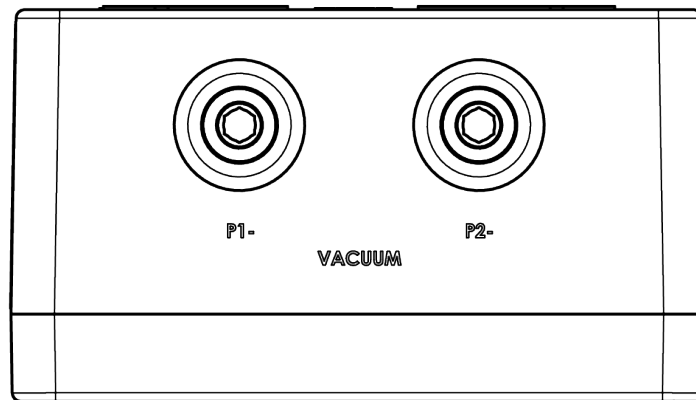

Fig. 3-17: PowerPick10 Vacuum Generator - Top View

3.6. Electrical Installation

3.6.1. PowerPick10 Vacuum Generator

1. Connect the M12 connector of the I/O cable to the PowerPick10 Vacuum Generator using the port identified as "device control."
2. Connect the open end of the I/O cable to the robot control box according to the table and figure below.
3. Complete the ground (GND) connection by securing the green cable's ring connector to an M6 protective earth stud with the two (2) M6 external tooth lock washers provided and one (1) M6 flange nut (tool not supplied).
4. Tighten the nut so that the lock washers are properly engaged.





NOTICE

Refer to the figure (Fig. 3-14) below for an example of the ground connection.

Below are examples of the electrical connections when working with a UR10e robot.

Color	Connection	Function
Red	AG (Analog Ground)	0 V Pressure Sensor #1 (S1)
Violet	AI (Analog Input)	AI Pressure Sensor #1 (S1)
Red/Blue	AG (Analog Ground)	0 V Pressure Sensor #2 (S2)
Gray/Pink	AI (Analog Input)	AI Pressure Sensor #2 (S2)
Blue	0V	0 VDC
Pink	DO (Digital Output)	Suction #1 (Y1)
Yellow	DO (Digital Output)	Suction #2 (Y2)
Black	DO (Digital Output)	Blow off #1 (Y3)
Gray	DO (Digital Output)	Blow off #2 (Y4)
Brown	24 V	24 VDC
Green	GND (Ground)	Ground

Table 3-2: Identification of I/O Cable Connections

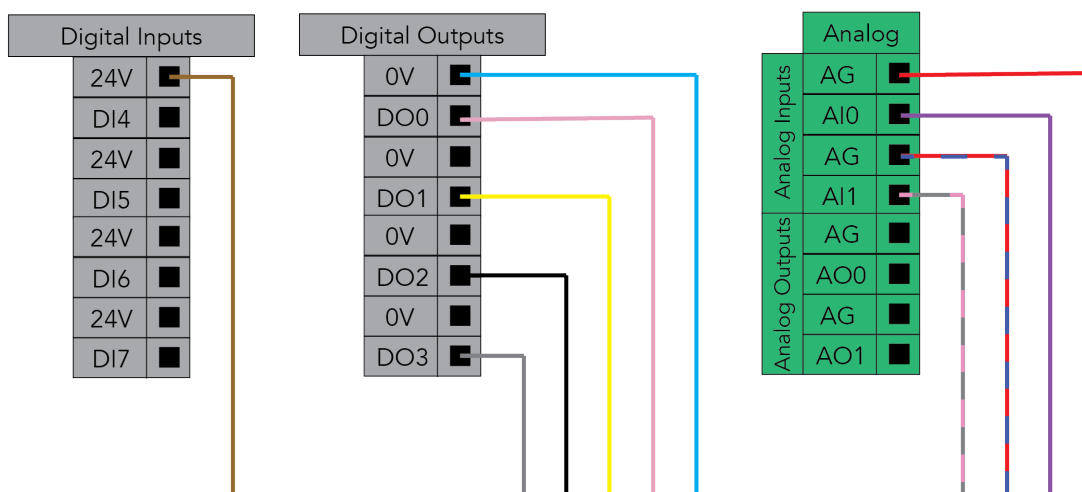

Fig. 3-18: PowerPick10 Vacuum Generator Connections to Robot Control Box



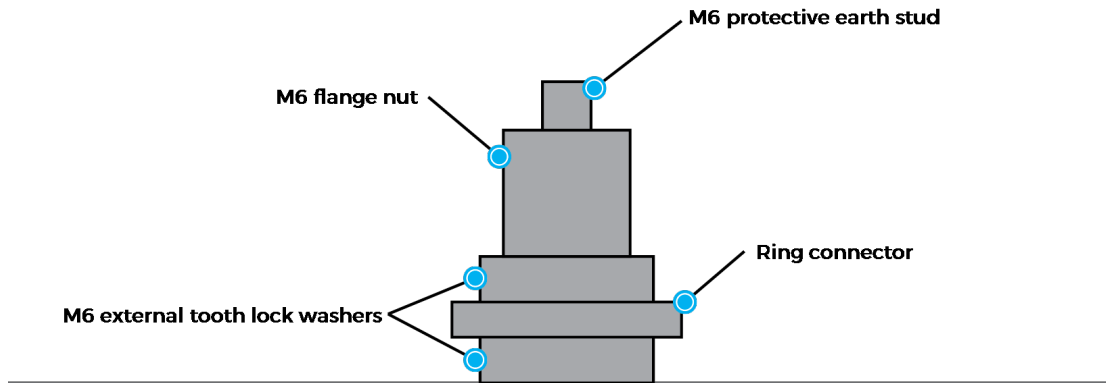

Fig. 3-19: Schematic Figure of Ground Connection



Fig. 3-20: Example of Ground Connection in Robot Control Box





NOTICE

When the PowerPick10 Vacuum Gripper is used with either the PE10 or AX10 Robotiq Palletizing Solution, follow the electrical installation instructions found in the corresponding Palletizer user manual.

3.7. Supply Pressure Adjustment

The optimal pressure for compressed air consumption is 6 bar (87 psi). However, it is possible to reduce the supply pressure in order to reduce air consumption or noise level. If so, further tests must be performed to ensure the payload is always maintained in operating conditions.

	CAUTION
<p>Make sure all pneumatic tubes connected to the Vacuum Generation Unit and the Vacuum Gripper are pushed all the way in.</p>	

	NOTICE
<p>The digital outputs are identified in the Electrical Installation section.</p>	

1. Open the shut-off valve by turning it in "SUP" position
2. Remove all objects from under the suction cups and activate both suction valves.
3. While the vacuum is activated, adjust the pressure to the desired value on the filter-regulator by turning the knob at the top.
4. Let the valves open for at least 30 seconds to stabilize the pressure (optimal pressure is 6 bar (87 psi)).
5. Deactivate both suction valves.
6. Validate the adjustment by repeatedly activating and deactivating both suction valves.
7. Verify the pressure value shown on the filter-regulator.

3.8. Configuration Steps and Tips

	NOTICE
<p>Please use the Robotiq Configurator to simulate the configuration that corresponds best to the application at hand. Should the application require more than one configuration, consider using a gripper arrangement that adapts to every situation.</p>	

3.8.1. TCP and Center of Mass

Refer to the **Tool Center Point** and **Center of Mass** section to identify the values that correspond to the configuration



3.8.2. Choice of Suction Cups

Choose the suction cups according to the weight and surface condition of the items to be moved.

Component		Typical use
52 mm suction cups ¹		Items less than 6 kg (13 lb)
75 mm suction cups		Items between 6 and 11 kg (13 and 24 lb)
78 mm suction cups ¹		Recommended for heavy porous items

¹ Optional components

Table 3-3: Suction cups for PowerPick10 Standard Gripper

Component	Porous item	Non-porous item
52 mm suction cup ¹	Items less than 1.5 kg (3.3 lb)	Items less than 2.5 kg (5.5 lb)
75 mm suction cup	Items less than 3.0 kg (6.6 lb)	Items less than 5.0 kg (11.0 lb)
90 mm suction cup ¹	Items less than 4.5 kg (9.9 lb)	Items less than 6.5 kg (14.3 lb)

¹ Optional components

Table 3-4: Suction cups for PowerPick10 Single Cup Gripper



3.8.3. Choice of Suction Cup Brackets

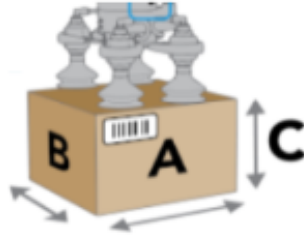







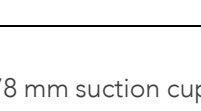

Fig. 3-21: A-B-C box dimensions

Component combinations		Item dimensions	
		Metric	Imperial
Small suction cup brackets 	52 mm suction cups 	A: 200+ mm B: 140+ mm	A: 7-7/8+ in B: 5-1/2+ in
	75 mm suction cups 	A: 230+ mm B: 165+ mm	A: 9+ in B: 6-1/2+ in
	78 mm suction cups 	A: 235+ mm B: 170+ mm	A: 9-1/4+ in B: 6-5/8+ in
Large suction cup brackets 	52 mm suction cups 	A: 340+ mm B: 210+ mm	A: 13-3/8+ in B: 8-1/4+ in
	75 mm suction cups 	A: 345+ mm B: 220+ mm	A: 13-1/2+ in B: 8-5/8+ in
	78 mm suction cups 	A: 375+ mm B: 240+ mm	A: 14-3/4+ in B: 9-3/8+ in





			
Single cup bracket 	52 mm suction cups	A: 58+ mm B: 58+ mm	A: 2-5/16+ in B: 2-5/16+ in
	75 mm suction cups	A: 81+ mm B: 81+ mm	A: 3-3/16+ in B: 3-3/16+ in
	90 mm suction cups	A: 96+ mm B: 96+ mm	A: 3-3/4+ in B: 3-3/8+ in

Table 3-5: Combinations of suction cups and suction cup brackets

	NOTICE
	To ensure stability when operating the Gripper, always position the Gripper so that it is aligned with the center of the box, with the suction cups as close to the edge of the box as possible.

3.8.4. Wrist Extension

Install the wrist extension if additional vertical reach is required.

Component	Additional vertical reach
Wrist extension 1 	120 mm (4-3/4 in)

¹ Wrist extension is mandatory with the 0 mm offset plate.

Table 3-6: Wrist extension



Fig. 3-22: Wrist Extension with 200 mm Hollow Offset Link and Small Suction Cup Brackets



Fig. 3-23: Wrist Extension with Single Cup bracket

3.8.5. Choice of X-Axis Offset Component

Choose the offset component based on the required X-axis reach and the weight of the items to be moved.

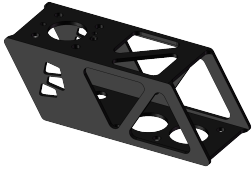
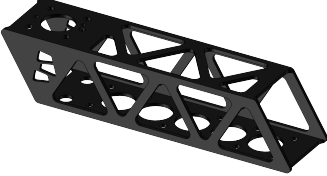
Component		Payload ³
0 mm offset plate 1-2		Items up to 11.3 kg (24.9 lb)
100 mm hollow offset link		Items up to 11.3 kg (24.9 lb)
200 mm hollow offset link		Items up to 8.3 kg (18.3 lb)

¹ Requires the use of the wrist extension.

² Cannot be used with the Single Cup bracket.

³This value is only valid for the PowerPick10 Gripper used in conjunction with a UR10 robot. The payload may be limited by the robot used. Please refer to the user manual of the robot for additional information.

Table 3-7: X-Axis Offset components





Fig. 3-24: 0 mm Offset Plate with Large Suction Cup Brackets

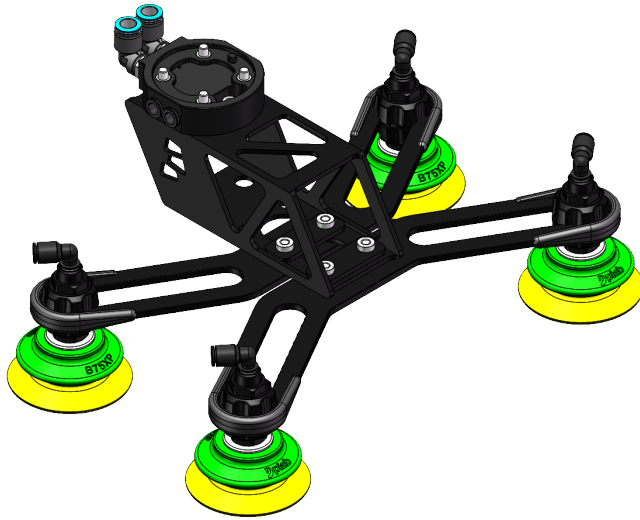

Fig. 3-25: 100 mm Hollow Offset Link with Large Suction Cup Brackets

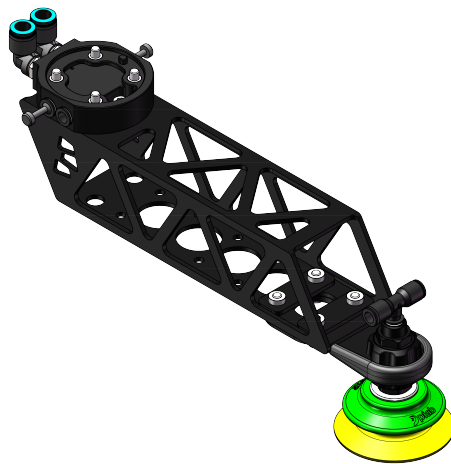

Fig. 3-26: 200 mm Hollow Offset Link with the Single Cup Bracket

Holes on 100 mm and 200 mm Hollow Offset Links

The suction cup brackets can be installed on any pair of holes along the offset links.

The 200 mm hollow offset link has six (6) pairs of holes, resulting in fifteen (15) possible positions for the small and large suction cup brackets, and four (4) possible positions for the Single cup bracket.

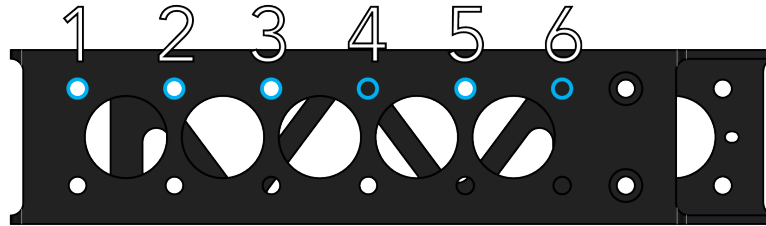

Fig. 3-27: Holes for Suction Cup Brackets on 200 mm Hollow Offset Link

The 100 mm hollow offset link has five (4) pairs of holes, resulting in six (6) possible positions for the small and large suction cup brackets, and two (2) possible positions for the Single cup bracket.

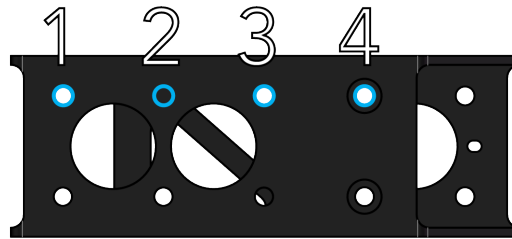

Fig. 3-28: Holes for Suction Cup Brackets on 100 mm Hollow Offset Link



4. Software

4.1. URCap Package on E-Series

	NOTICE
	PowerPick 20/30 URCap is compatible only with on e-Series.

Robotiq provides you with a Universal Robots URCap package that enables direct serial communication to your robot controller.

	NOTICE
	To download the URCap package for your Universal Robots controller, go to robotiq.com/support , select your product and robot brand from the list, then go to Software > Gripper Software > DOWNLOAD ZIP .

Make sure the PowerPick is properly mounted to the robot arm and that the payload and the center of gravity are adjusted. Refer to the Mechanical Installation section for detailed information on the mechanical installation.

- The Gripper URCap package installs the following elements:
 - Gripper URCap
 - Gripper Toolbar
 - Gripper nodes

	CAUTION
	The robot's PolyScope version must be 5.16.0+ in order to install the URCap. To identify your PolyScope version, go to the PolyScope home page and tap About. A window containing the Universal Robots software version is then displayed.



4.1.1. Installing URCap Package

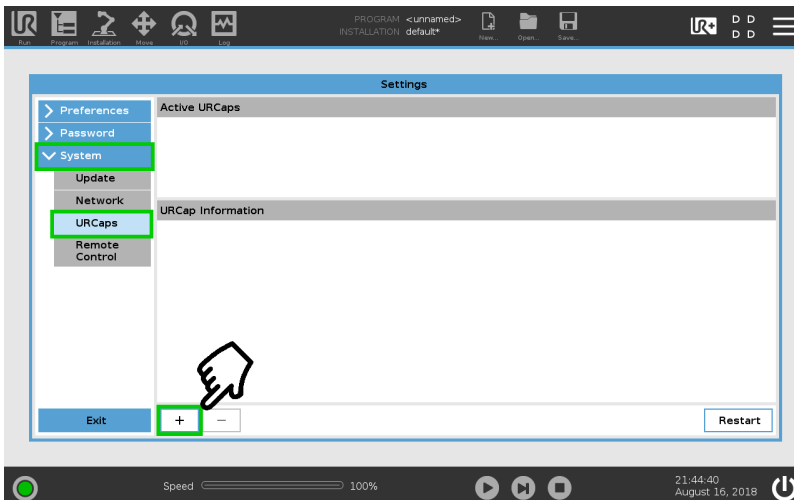
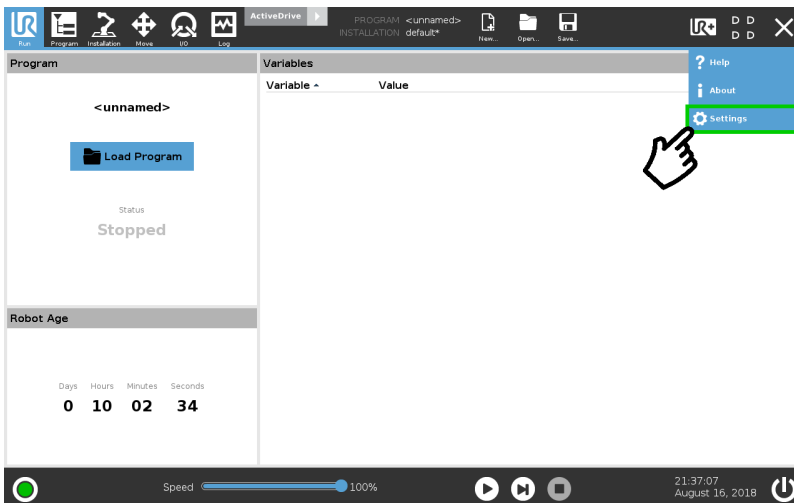
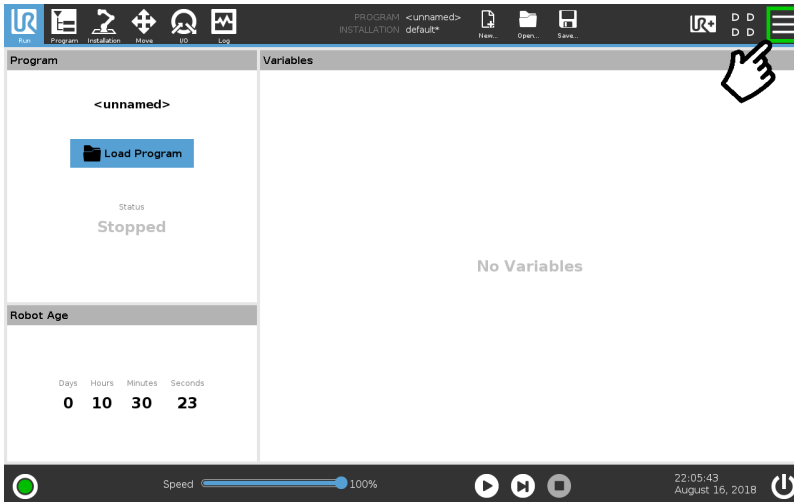

- Make sure that your PolyScope version is up-to-date and that your Universal Robots controller is compatible with the Gripper's URCap package.
- Browse to support.robotiq.com and click on **Select product > Vacuum Gripper > Universal Robots > Software > Gripper Software**.
- Download the **UCG-3.9.0+** and extract its content on the root of a blank USB stick.
- Insert the USB stick in the UR teach pendant or controller.
- On the teach pendant, tap the **triple bar icon** in the upper right corner of the screen.
- Tap **Settings**.
- Tap the **System** button in the navigation pane on the left.
- Select **URCaps** in the dropdown list.
- Press the plus (+) button to look for the .urcap file in the available drives.
- Once the file is selected, it will display in the **Active URCaps** box, next to a rounded arrow.
- Tap the **Restart** button to activate the URCap.



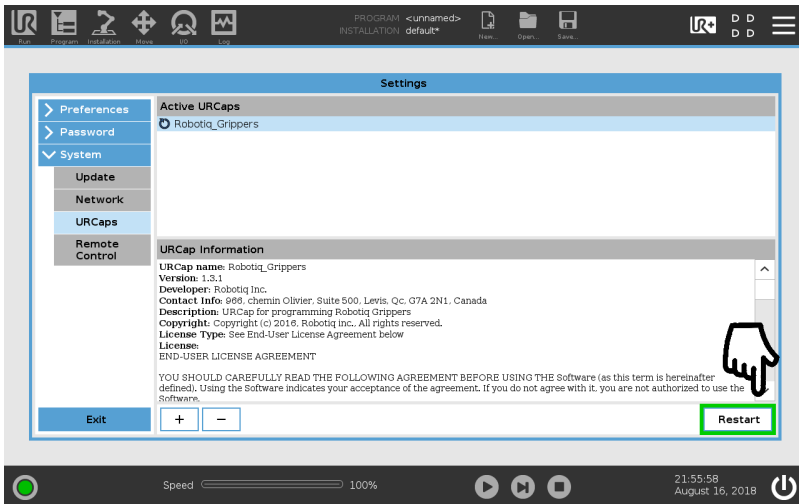

4.1.2. Uninstalling URCap Package

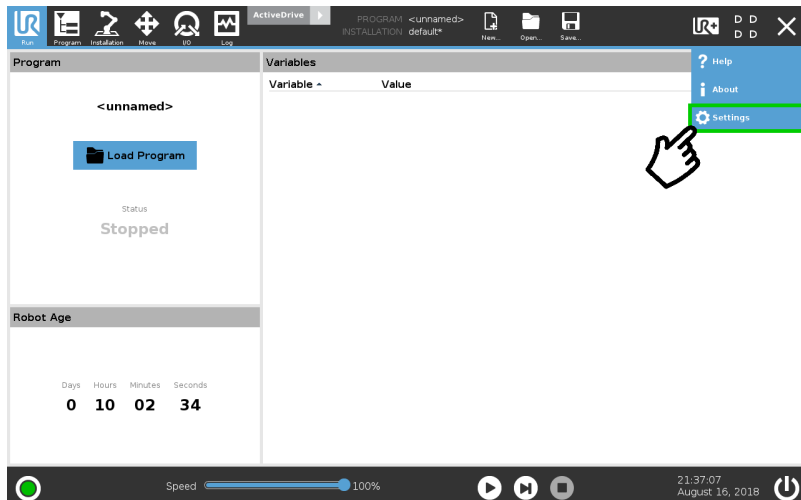
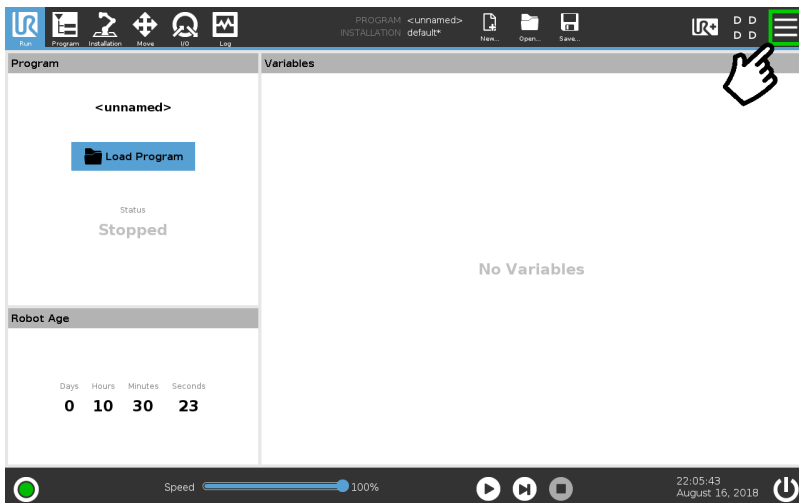

- On the teach pendant, tap the **triple bar** icon in the upper right corner of the screen.
- Tap **Settings**.



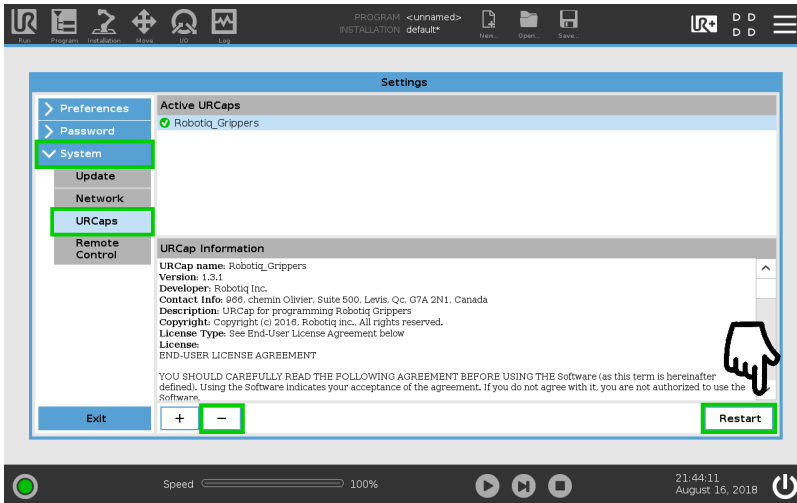

- Tap the **System** button in the navigation pane on the left.
- Select **URCaps** in the dropdown list.
- Select the URCap to uninstall.
- Press the minus (-) button to remove the URCap.
- Tap the **Restart** button to deactivate the URCap.

4.2. Vacuum Gripper Selection

- In the Installation tab, under URCaps/Vacuum, select PowerPick as the vacuum gripper model.
- Depending on the gripper used, activate gripper zones. 1 should be used for a single channel vacuum generator and 2 for a dual channel one.
- To have automatic IO selection, under General/I/O Setup rename the digital outputs and analog inputs the following way:
 - ppick_blowoff_1
 - ppick_vacuum_1
 - ppick_vac_lm_1
 - ppick_blowoff_2
 - ppick_vacuum_2
 - ppick_vac_lm_2
- Select the appropriate digital outputs for the blowoff and vacuum of each zone as well as the analog inputs for the vacuum level of each zone. If named correctly, the selection should be automatic.
- Test each to make sure the right outputs are selected.



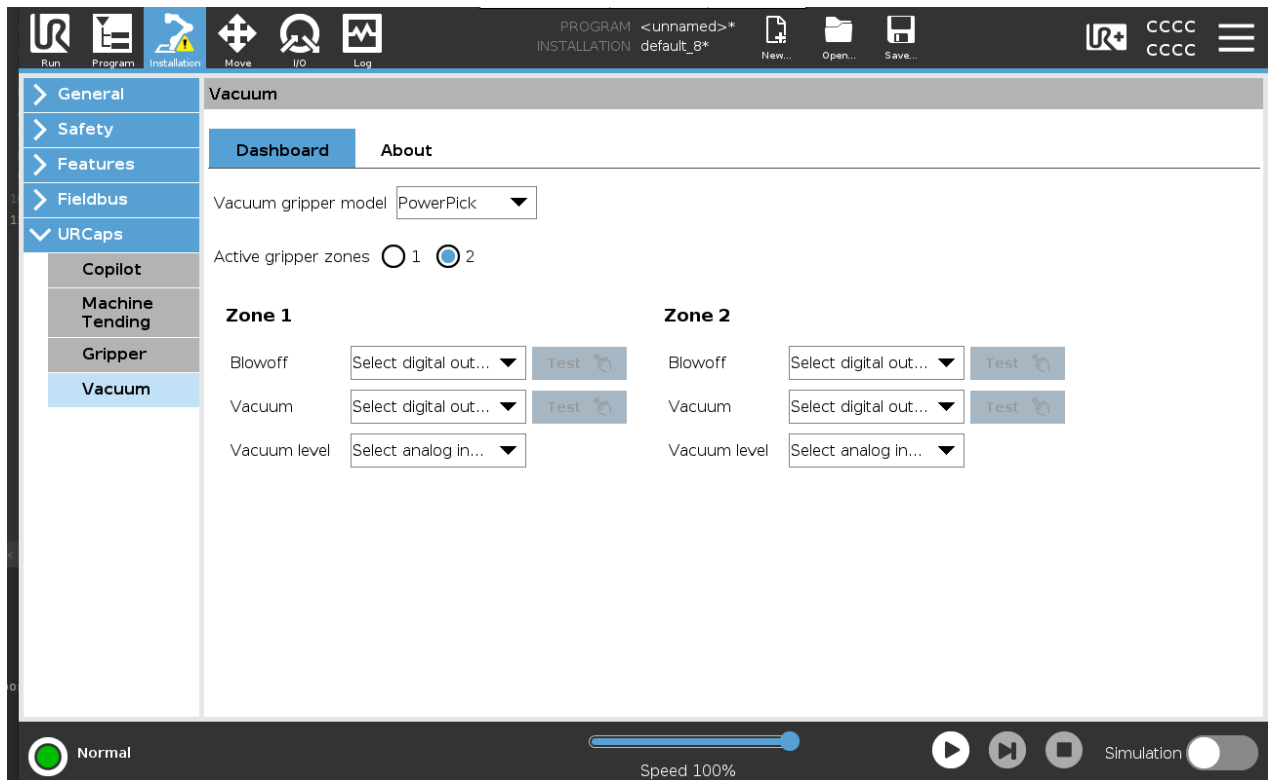

Fig. 4-1: Vacuum Gripper Settings

4.3. Vacuum Gripper Toolbar

4.3.1. Overview

The Vacuum Gripper Toolbar is used to test the gripper.

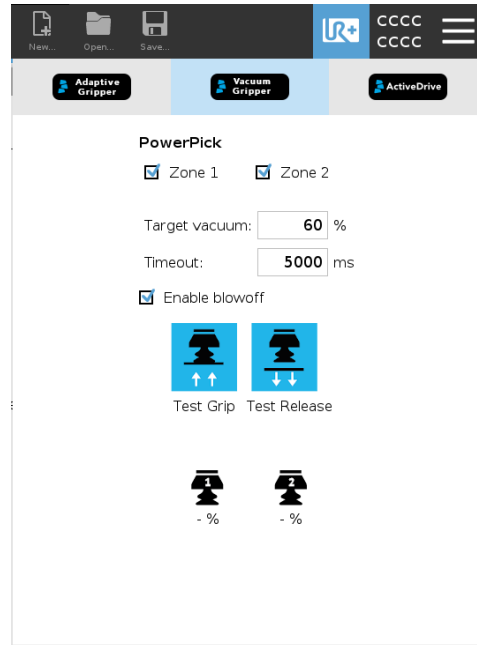

Fig. 4-2: Vacuum Gripper Toolbar

4.3.2. Features

Functionality name	Description
Zones	Selects which zone to use.
Target vacuum	Sets a target vacuum level to reach
Timeout	Allows to set a time in which the robot will call a timeout if the target vacuum level is not reached.
Enable blowoff	Enables blowoff during the release
Test Grip/Release	Performs a Grip/Release test corresponding to the Grip mode selected
Vacuum level	Gives the vacuum level of each zones in real time

4.4. PowerPick node

Adding and editing a PowerPick node inside a robot program is done by following these steps:

1. On the teach pendant, at the top of the screen, tap the **New** icon to create a program or the **Open** icon to load an existing program.



2. Select **Program**. The Program window will display.
3. Tap the **URCaps** menu in the navigation pane on the left.
4. Tap the **Vacuum** button.
5. Select the node in the robot program and tap the **Command** tab.

4.4.1. Grip Command

The Grip command window shows the requested action parameters for the PowerPick grip.

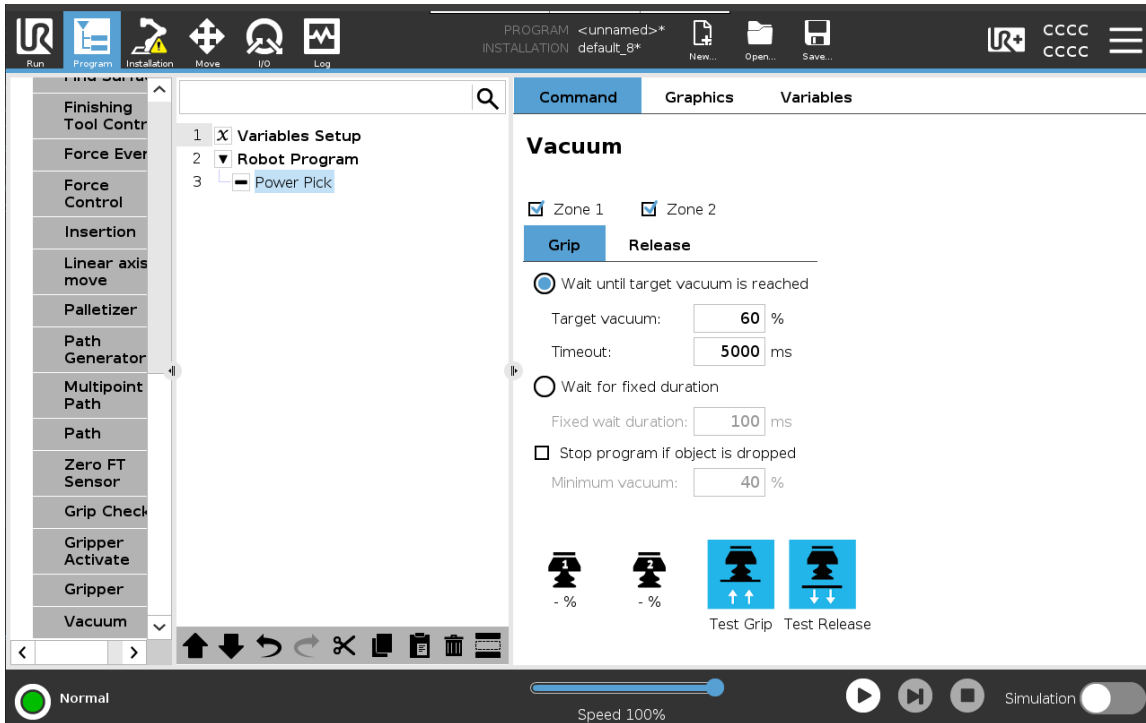

Fig. 4-3: Grip Command Window from the PowerPick Node

The command window has the same functionalities as the vacuum gripper toolbar and additional ones.

Functionality name		Description
Zones		Selects which zone to use.
Wait until the target vacuum is reached	Target vacuum	Allows the robot to wait for the Target vacuum , set in this functionality, to be reached before any other action. If the Timeout is reached before the target vacuum level, a pop-up will appear on the teach pendant.
	Timeout	
Wait for fixed duration	Fixed wait duration	Allows the robot to wait for the Fixed wait duration set in this functionality before any other action. It will not get a precise vacuum level in this case.
Stop program if object is dropped	Minimum vacuum	Will stop the program whenever the Minimum vacuum level is reached after a grip. It allows to stop the program if a box is dropped or partially. In a case this occurs, the robot won't cut the vacuum. This allows the robot not to drop the object if it's still gripped. A grip check error pop-up will appear.
Vacuum level		Gives the vacuum level of each zone in real time
Test Grip/Release		Performs a Grip/Release test.



4.4.2. Release Command

The Release command window shows the requested action parameters for the PowerPick release.

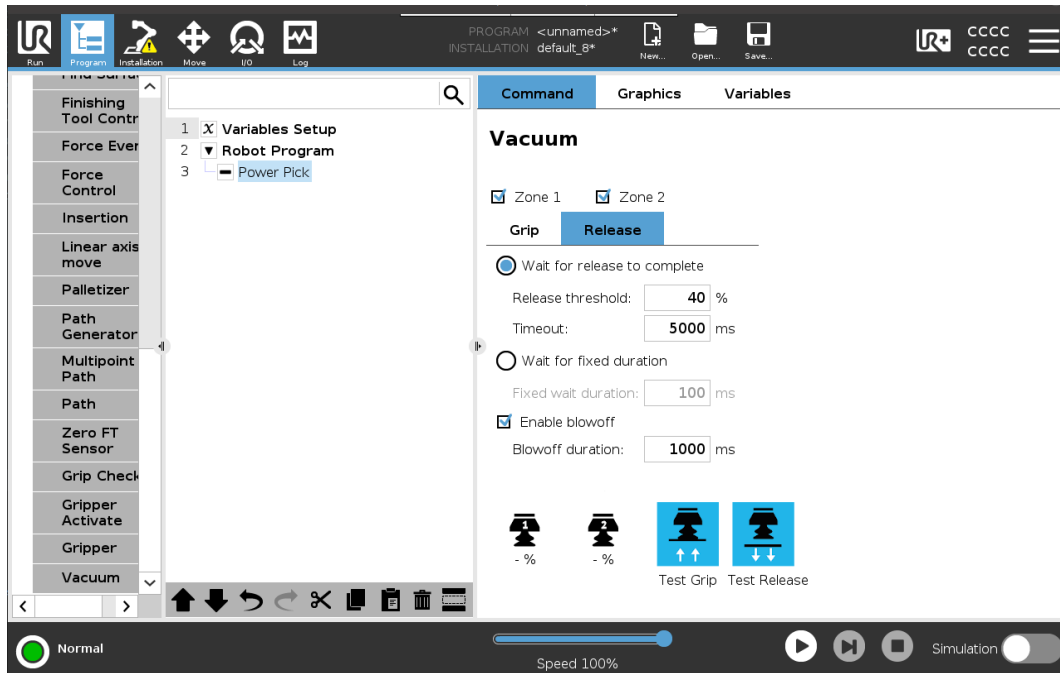

Fig. 4-4: Release Command Window from the PowerPick Node

Functionality name		Description
Zones		Selects which zone to use.
Wait for release to complete	Release threshold	Allows the robot to wait for the Release threshold , set in this functionality, to be reached before any other action. If the Timeout is reached before the release threshold, a pop-up will appear on the teach pendant.
	Timeout	
Wait for fixed duration	Fixed wait duration	Allows the robot to wait for the Fixed wait duration set in this functionality before any other action. It will not get a precise vacuum level in this case.
Enable blowoff	Blowoff duration	This will activate the blowoff at the release. The time of the blowoff can be set in this functionality.
Vacuum level		Gives the vacuum level of each zone in real time
Test Grip/Release		Performs a Grip/Release test.



5. Specifications



NOTICE

This manual uses the metric system. Unless specified, all dimensions are in millimeters.

5.1. Technical dimensions

5.1.1. PowerPick10 Vacuum Generator

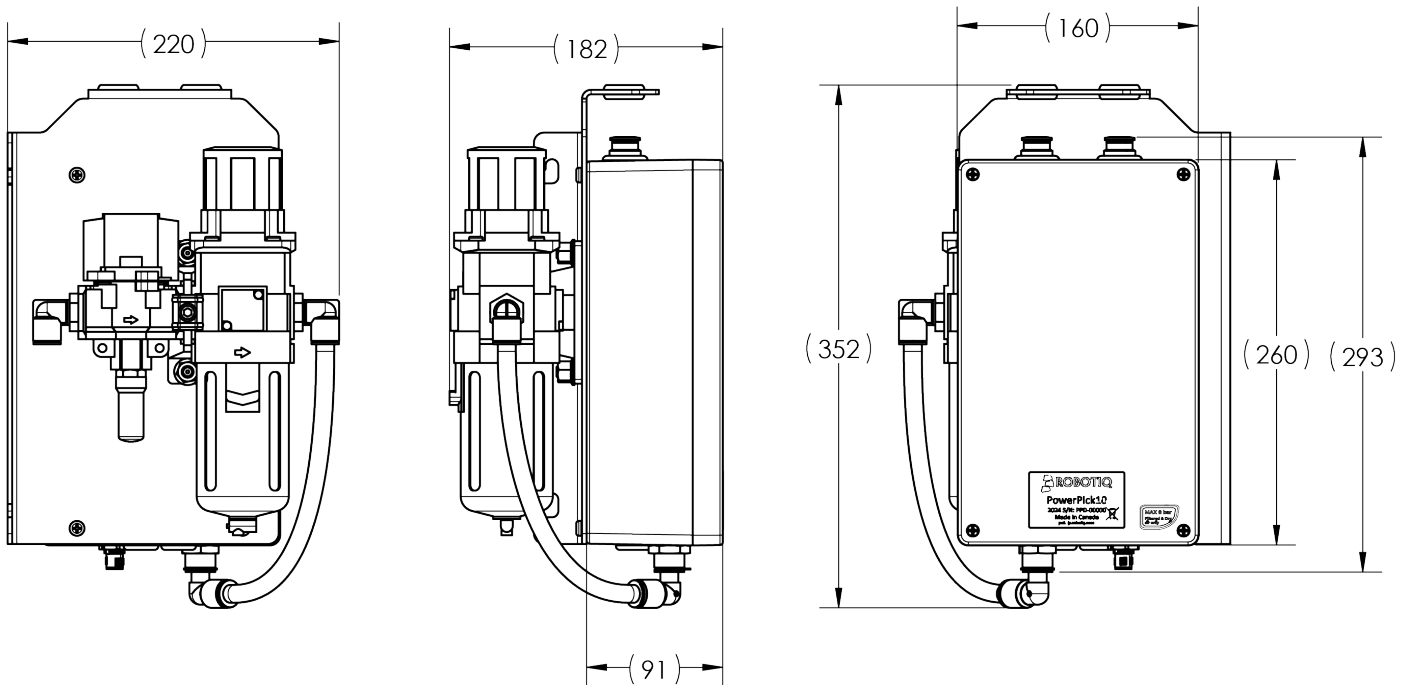

Fig. 5-1: Dimensions of PowerPick10 Vacuum Generation Unit



5.1.2. 200 mm Hollow Offset Link

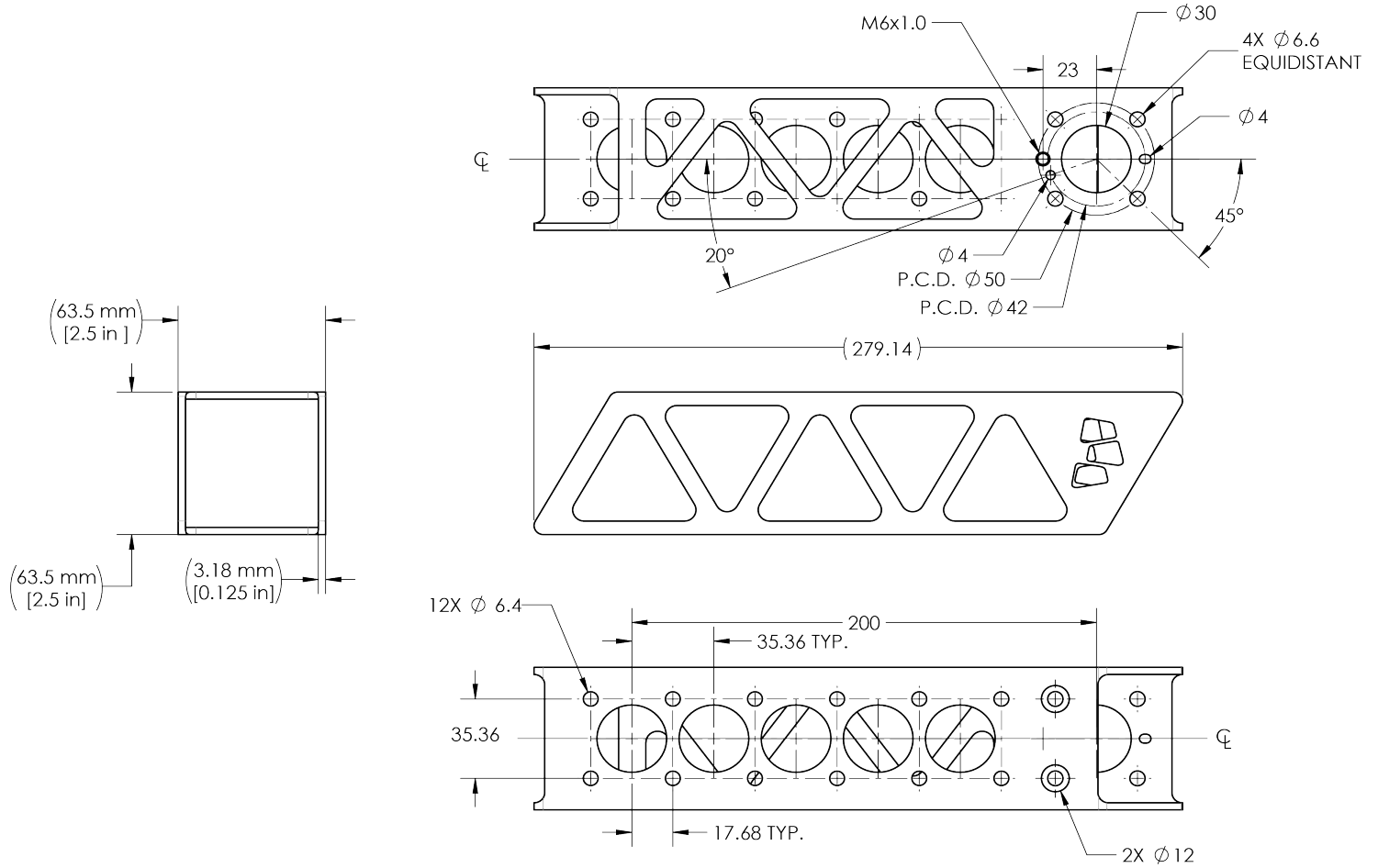

Fig. 5-2: Technical Dimensions of the 200 mm Hollow Offset Link

5.1.3. 100 mm Hollow Offset Link

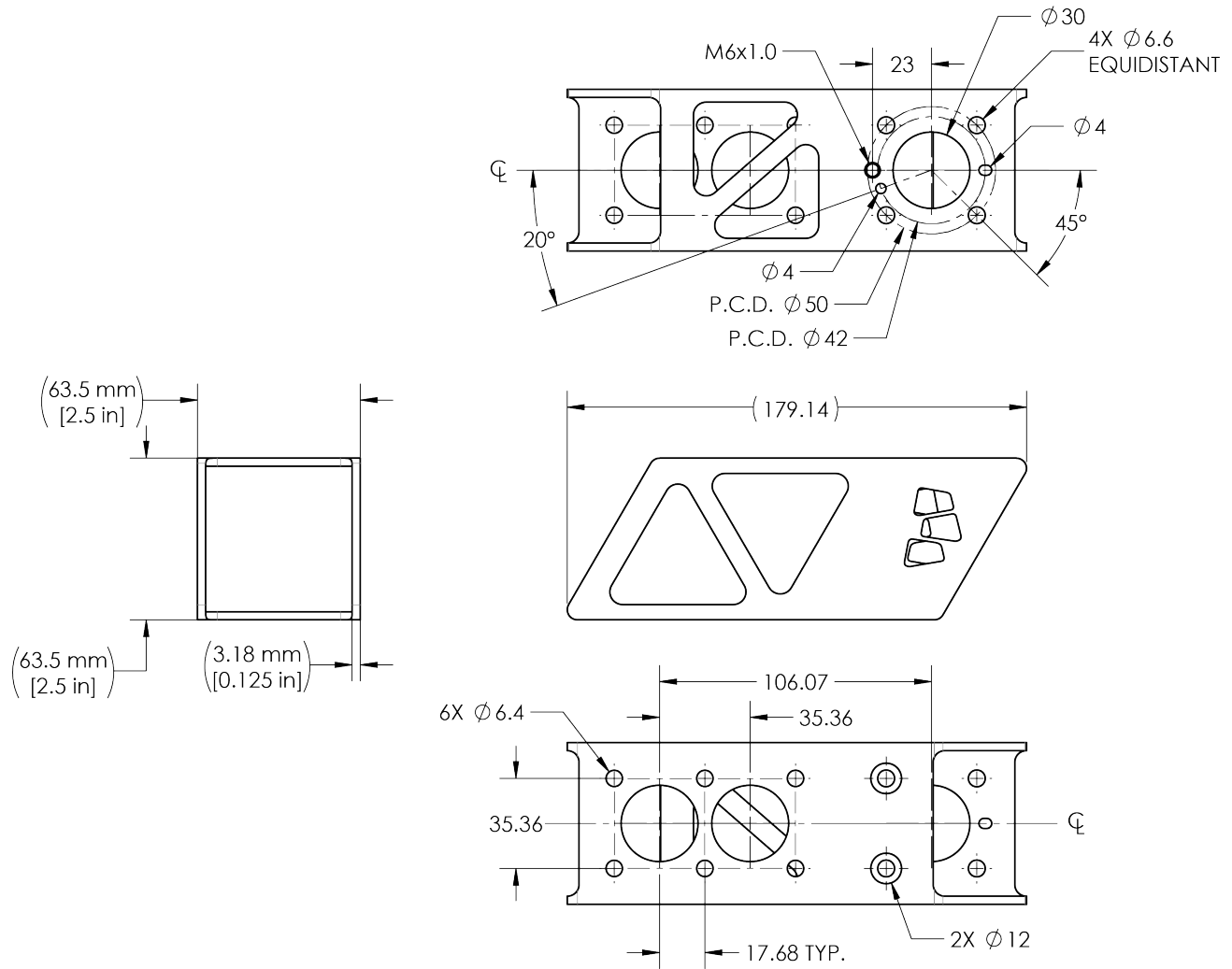

Fig. 5-3: Technical Dimensions of the 100 mm Hollow Offset Link



5.1.4. Small Suction Cup Bracket

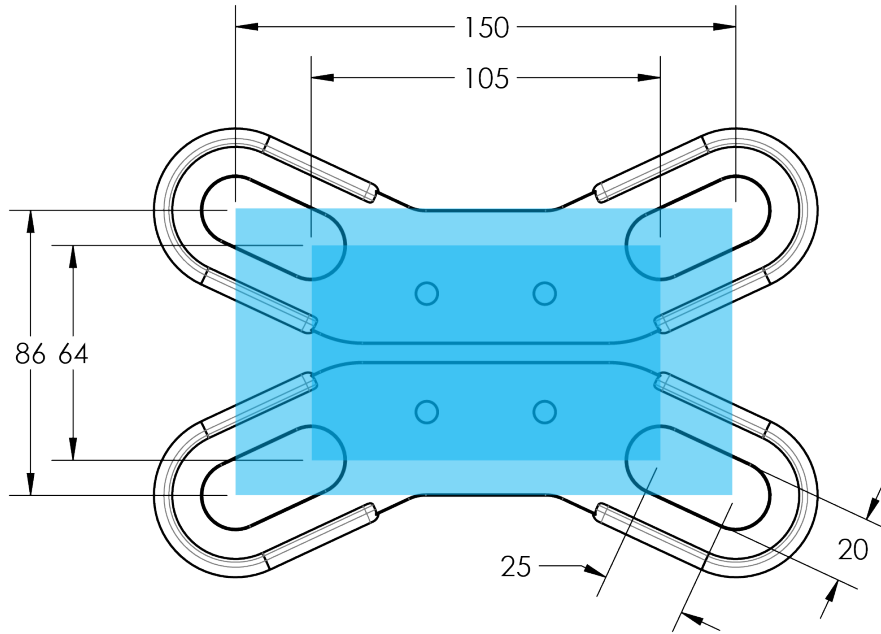

Fig. 5-4: Technical dimensions of the Small Suction Cup Brackets

5.1.5. Large Suction Cup Bracket

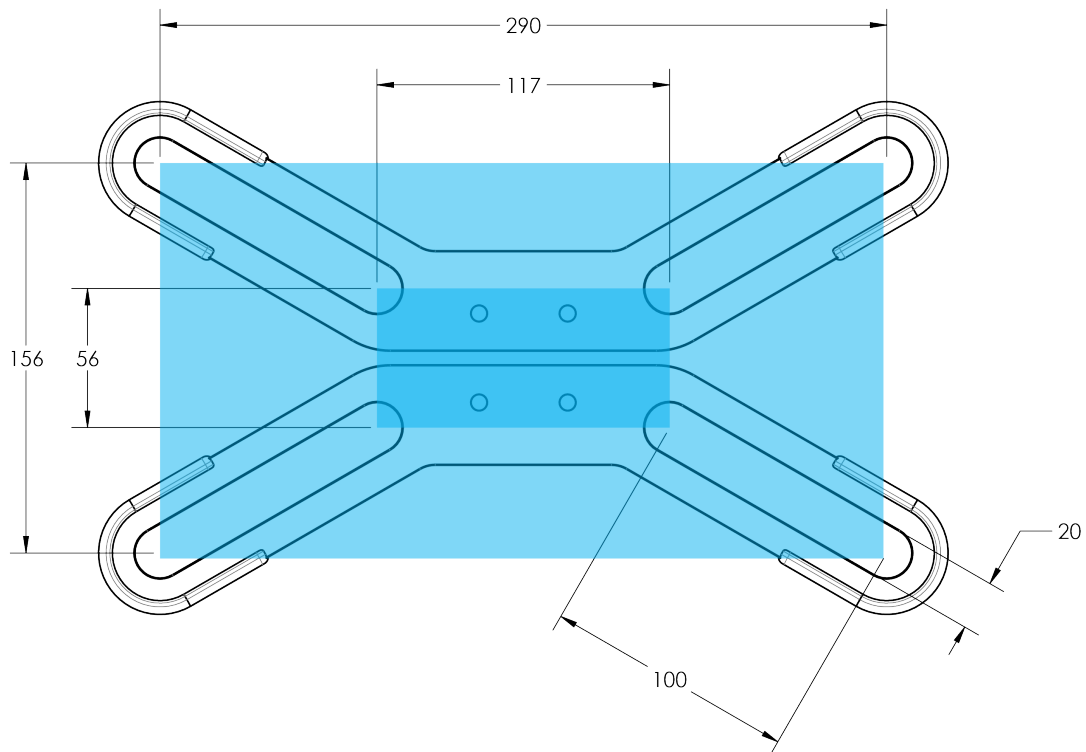

Fig. 5-5: Technical Dimensions of the Large Suction Cup Brackets

5.1.6. Single Cup Bracket

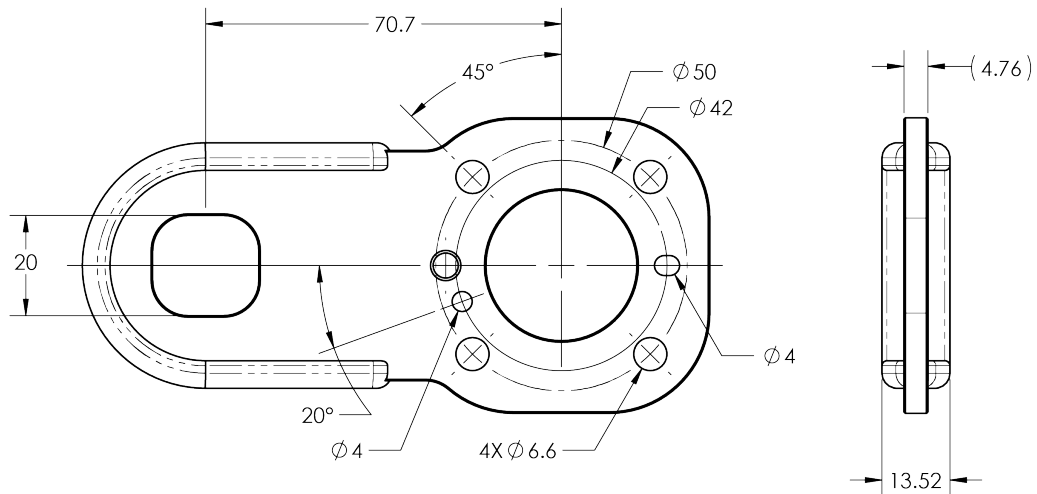

Fig. 5-6: Technical Dimensions of the Single Cup bracket

5.1.7. Air Node

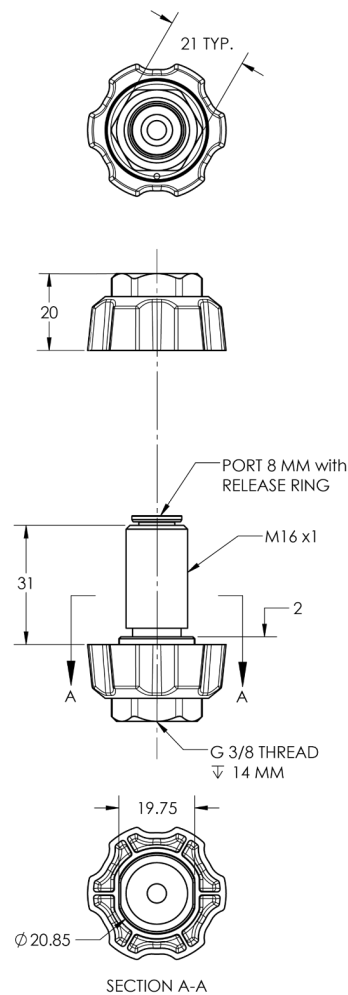

Fig. 5-7: Technical Dimensions of the Air Node



5.1.8. Wrist Extension

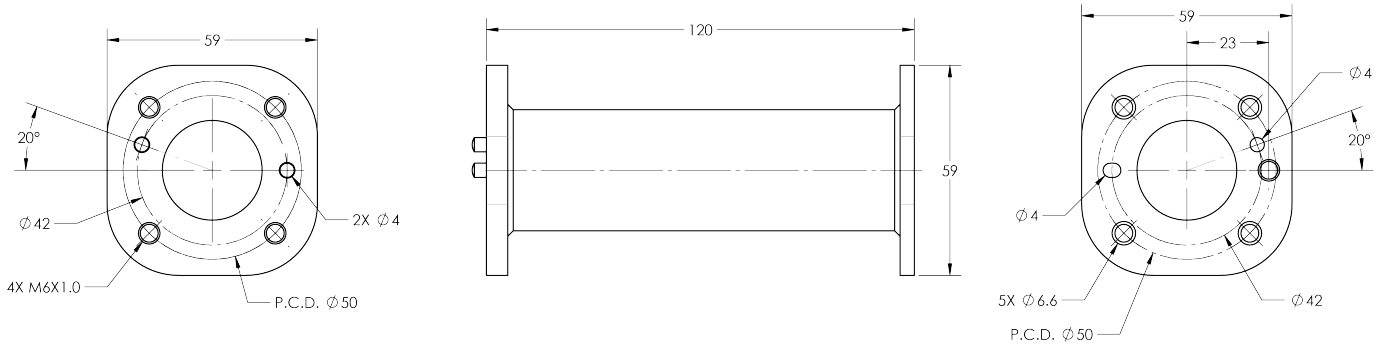

Fig. 5-8: Technical Dimensions of the Wrist Extension

5.1.9. 0 mm Offset Plate

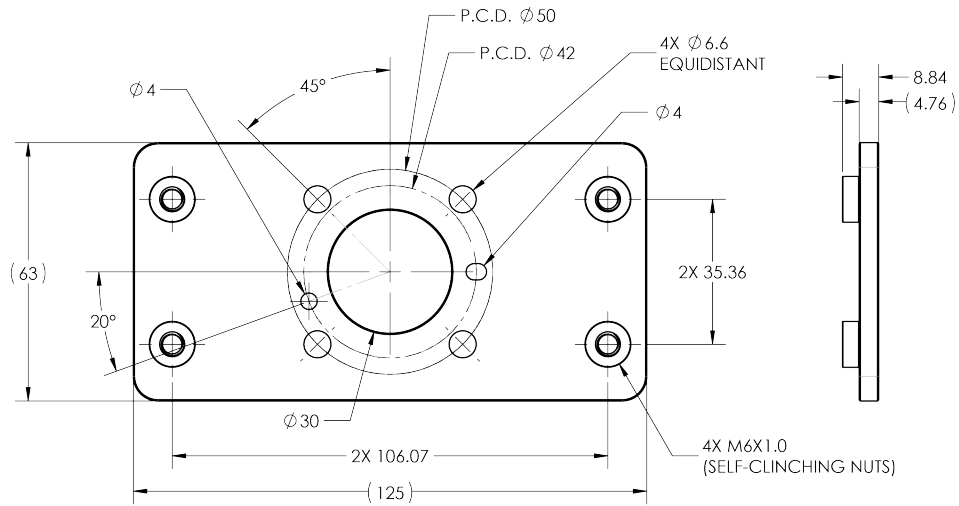

Fig. 5-9: Technical Dimensions of the 0 mm Offset Plate

5.1.10. PowerPick10 Standard Gripper (Default Configuration)

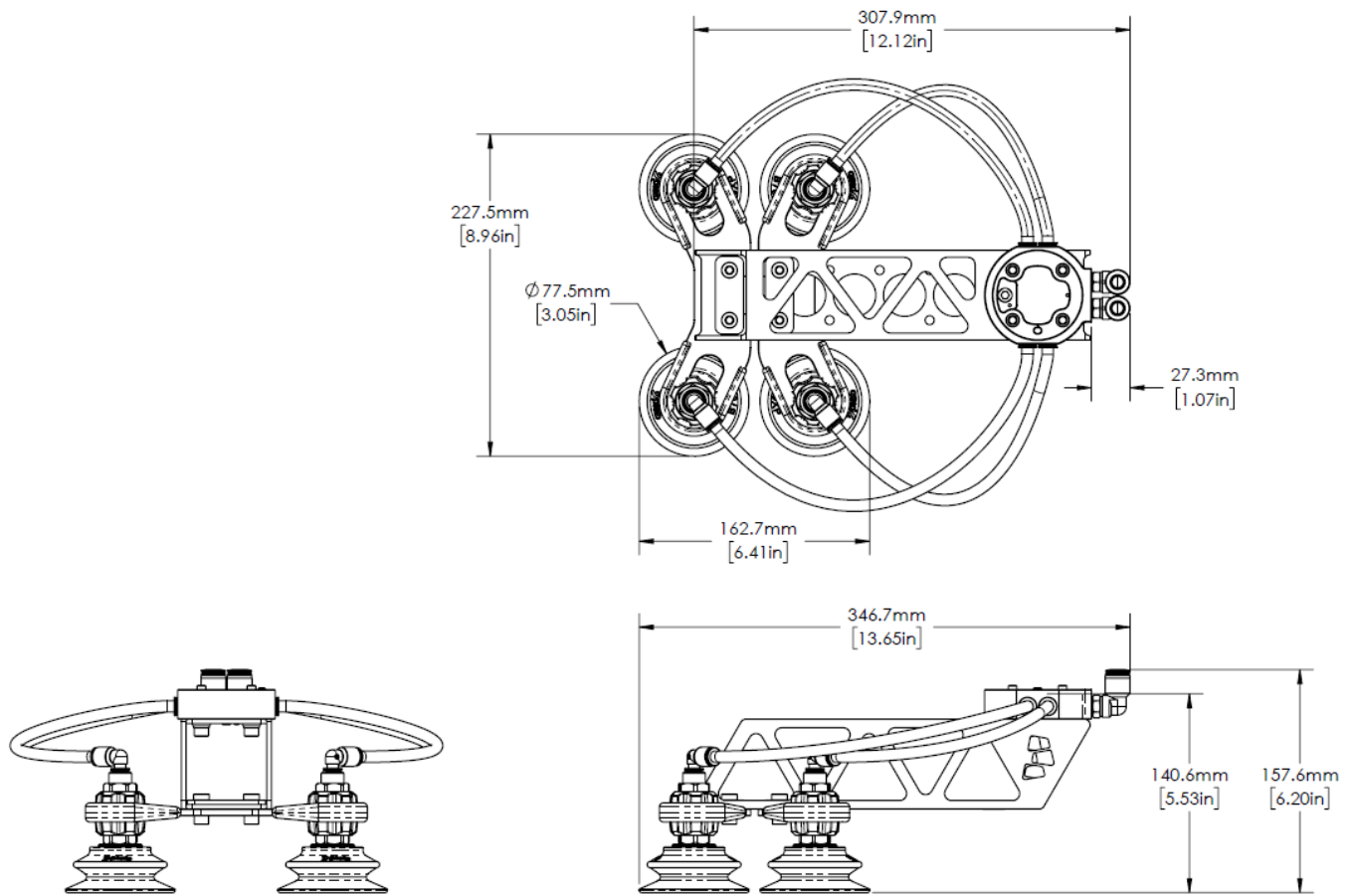

Fig. 5-10: Technical Dimensions of PowerPick10 Standard Gripper (Default Configuration)



5.1.11. PowerPick10 Single Cup Gripper (Default Configuration)

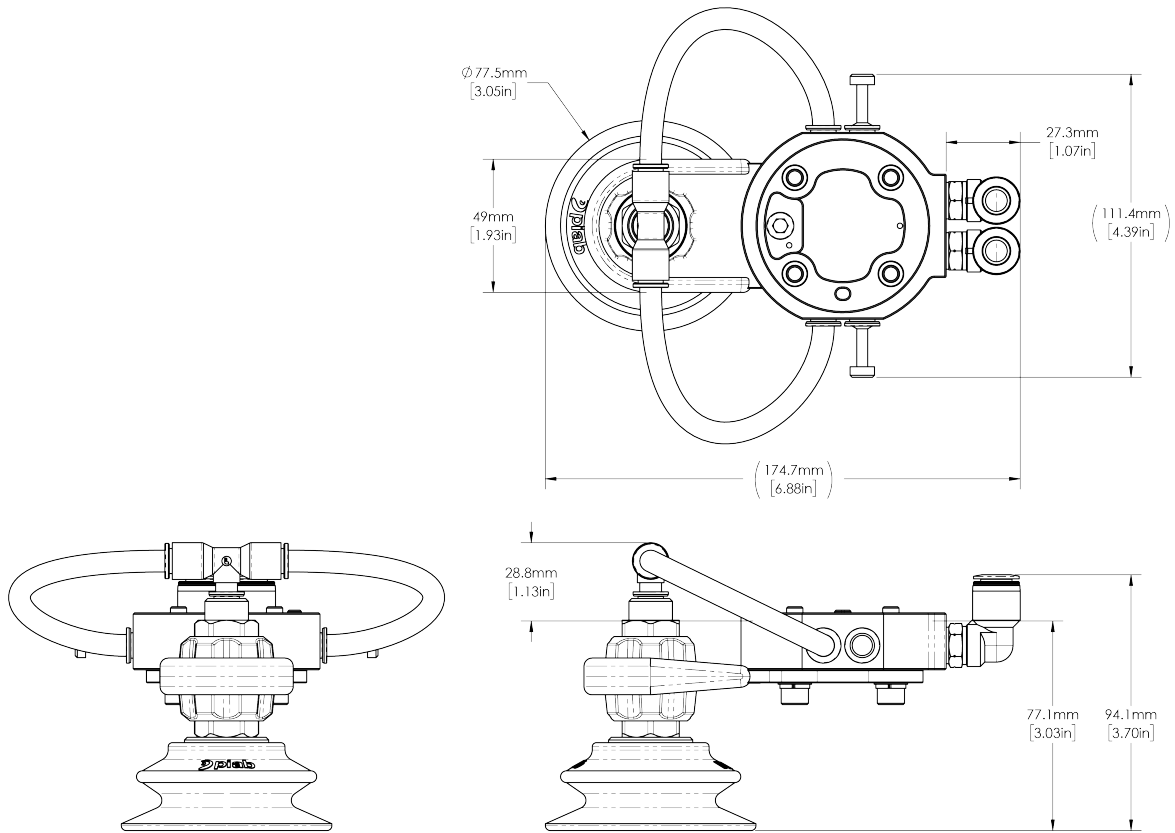

Fig. 5-11: Technical Dimensions of PowerPick10 Single Cup Gripper (Default Configuration)

5.2. Mechanical Specifications

5.2.1. PowerPick10 Vacuum Gripper

Specification		Value	
		Metric	Imperial
Energy source		Compressed air and electricity	
Gripper mass		Refer to the Tool Center Point and Center of Mass section.	
Vacuum Generation Unit mass		6.7 kg	14.6 lb
Air tube to Vacuum Generator		12 mm OD	N/A
Air tube to Gripper		12 mm OD	N/A
Suction Cup Thread		G 3/8	3/8-19 BSPP
Gripping time	PowerPick10 Standard	0.4 s	
	PowerPick10 Single Cup	0.2 s	
Release time (with blow off)	PowerPick10 Standard	0.1 s	
	PowerPick10 Single Cup	0.05 s	
Minimum feed pressure		3 bar	43.5 psi
Optimal feed pressure for compressed air consumption		6 bar	87 psi
Maximum feed pressure		8 bar	116 psi
Maximum vacuum at optimal feed pressure		92%	
Air consumption at minimum pressure		157 lpm	5.5 CFM
Air consumption at optimal pressure		266 lpm	9.4 CFM
Air consumption at maximum pressure		305 lpm	10.8 CFM



Maximum vacuum flow at optimal feed pressure		180 lpm	6.4 CFM
Maximum acceleration in operating conditions		1.5 G ¹	
Maximum acceleration in emergency stop situations		3.5 G ¹	
Maximum payload ²	PowerPick10 Standard	11.3 kg	24.9 lb
	PowerPick10 Single Cup	6.5 kg	14.3 lb
Noise level at optimal pressure		76 dBA	
Required media		Dry and filtered air as per ISO 8573-1 class 7.4.4	

¹ Includes gravitational acceleration.

² This value is only valid for the PowerPick10 Gripper used in conjunction with a UR10 robot. The payload may be limited by the robot used. Please refer to the robot user manual for additional information.

Table 5-1: Mechanical Specifications of PowerPick10 Vacuum Gripper

5.3. Tool Center Point and Center of Mass

All TCP, Center of mass and Mass values take into account four (4) 75 mm suction cups with the Small and Large brackets, and one (1) 75 mm suction cup with the Single Cup bracket. These values can vary depending on the suction cup used.

Configuration	Offset Component	Holes on offset link	Suction cup brackets	Wrist extension	TCP (mm)			Center of mass (mm)			Mass (g)
					X	Y	Z	X	Y	Z	
1 (default, Standard)	200 mm	1-2	Small	No	200	0	140	140	0	73	1206
2	200 mm	1-3	Small	No	182			130			
3	200 mm	1-4 / 2-3	Small	No	165			119			
4	200 mm	1-5 / 2-4	Small	No	147			108			
5	200 mm	1-6 / 2-5 / 3-4	Small	No	129			98			
6	200 mm	1-2	Small	Yes	200	0	260	121	0	162	1401
7	200 mm	1-3	Small	Yes	182			112			
8	200 mm	1-4 / 2-3	Small	Yes	165			103			
9	200 mm	1-5 / 2-4	Small	Yes	147			94			
10	200 mm	1-6 / 2-5 / 3-4	Small	Yes	129			84			
11	200 mm	1-2	Large	No	200	0	140	145	0	74	1313
12	200 mm	1-3	Large	No	182			134			
13	200 mm	1-4 / 2-3	Large	No	165			123			
14	200 mm	1-5 / 2-4	Large	No	147			112			
15	200 mm	1-6 / 2-5 / 3-4	Large	No	129			100			



16	200 mm	1-2	Large	Yes	200	0	260	127	0	165	1507
17	200 mm	1-3	Large	Yes	182			117			
18	200 mm	1-4 / 2-3	Large	Yes	165			107			
19	200 mm	1-5 / 2-4	Large	Yes	147			97			
20	200 mm	1-6 / 2-5 / 3-4	Small	Yes	129			88			
21	200 mm	1-2	Single Cup	No	271	0	140	113	0	53	716
22	200 mm	3-4	Single Cup	No	200			91			
23	200 mm	4-5	Single Cup	No	165			79			
24	200 mm	1-2	Single Cup	Yes	271	0	260	89	0	130	904
25	200 mm	3-4	Single Cup	Yes	200			71			
26	200 mm	4-5	Single Cup	Yes	165			62			
27	100 mm	1-2	Small	No	106	0	140	74	0	74	1121
28	100 mm	1-3	Small	No	88			63			
29	100 mm	1-4 / 2-3	Small	No	71			52			
30	100 mm	2-4	Small	No	53			40			
31	100 mm	3-4	Small	No	35			29			
32	100 mm	1-2	Small	Yes	106	0	260	64	0	162	1320
33	100 mm	1-3	Small	Yes	88			54			
34	100 mm	1-4 / 2-3	Small	Yes	71			44			
35	100 mm	2-4	Small	Yes	53			34			
36	100 mm	3-4	Small	Yes	35	25	0	140	0	75	1228
37	100 mm	1-2	Large	No	106	77					
38	100 mm	1-3	Large	No	88	65					
39	100 mm	1-4 / 2-3	Large	No	71	53					
40	100 mm	2-4	Large	No	53	41					
41	100 mm	3-4	Large	No	35	29	0	260	0	165	1427
42	100 mm	1-2	Large	Yes	106	67					
43	100 mm	1-3	Large	Yes	88	56					
44	100 mm	1-4 / 2-3	Large	Yes	71	46					
45	100 mm	2-4	Large	Yes	53	36					
46	100 mm	3-4	Large	Yes	35	26	0	140	0	54	634
47	100 mm	1-2	Single Cup	No	117	66					
48	100 mm	3-4	Single Cup	No	106	41	0	260	0	126	822
49	100 mm	1-2	Single Cup	Yes	117	51					
50	100 mm	3-4	Single Cup	Yes	106	31	0	201	0	123	1181
51	0 mm	-	Small	Yes	0	-2					
52	0 mm	-	Large	Yes	0	-2					
53 (default, Single Cup)	0 mm	-	Single Cup	No	71	0	76	22	0	20	385
54	0 mm	-	Single Cup	Yes	71	0	196	14	0	84	574

Table 5-2: TCP and Center of Mass for all PowerPick10 Gripper Configurations



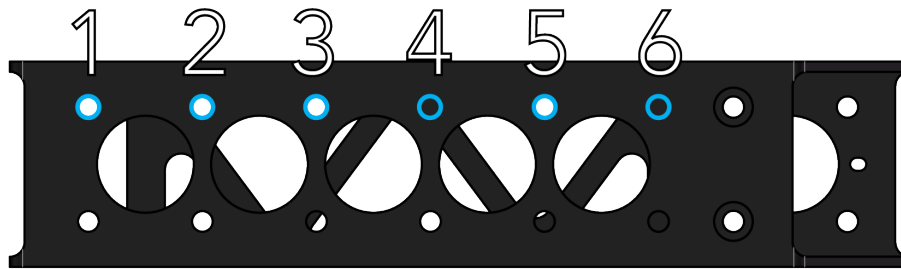

Fig. 5-12: Holes on 200 mm Hollow Offset Link

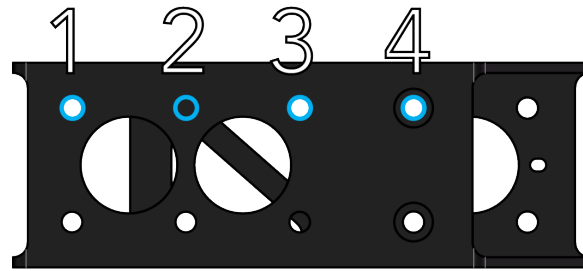

Fig. 5-13: Holes on 100 mm Hollow Offset Link

5.4. Electrical Specifications

5.4.1. PowerPick10 Vacuum Generator

Specification	Value
Nominal supply voltage	24 VDC \pm 10%
Quiescent power (minimum power consumption)	0.7 W
Peak current	200 mA
Hot swappable	Yes
ESD safe	No
Electrical connection	12-pole female M12 connector

Table 5-3: Electrical Specifications of PowerPick10 Vacuum Generator



5.5. Control specifications

Specification	Value
Communication protocol options	Digital I/O
Feedback	Vacuum level (1-5V analog)
Object detection (grip check)	Yes, via vacuum level

Table 5-4: Control Specifications of the PowerPick10 Gripper





6. Maintenance

The maintenance operations presented in this section are for the average normal usage of the Robotiq PowerPick10 Vacuum Gripper. The maintenance intervals must be adjusted according to the environmental conditions such as:

- Operating temperature
- Humidity
- Presence of chemical(s)
- Presence of physical objects (debris, scraps, dust, grease, etc.)
- Interaction with parts and objects (sharp or rough)
- Dynamics of the operation (e.g., accelerations).



The Vacuum Gripper only requires external maintenance with limited downtime. Following the maintenance interval will ensure:



- The correct functioning of the Vacuum Gripper;
- The validity of the warranty;
- The prescribed lifetime of the Vacuum Gripper.

	 CAUTION
	<ul style="list-style-type: none"> • Unless specified, any repair work performed on the PowerPick10 Vacuum Gripper must be done by Robotiq. • The warranty will be void if the PowerPick10 Vacuum Generator is opened by anyone other than a Robotiq employee.

6.1. Safety Measures



6.1.1. General Guidelines

	 WARNING
	<p>Before performing maintenance operations, make sure that the system is turned off and de-energized, and that it cannot be accidentally turned on.</p>

	 CAUTION
	<ul style="list-style-type: none"> • Maintenance must only be carried by qualified and authorized service personnel. • Refer to the Safety section for more safety instructions.



- All pneumatic tools and devices must be emptied before work.
- Always turn off and lock out electrical disconnect switches.

	 CAUTION
	<p>For maintenance on pneumatic components, install a lockout valve before connecting to the product.</p> <p>Always lockout prior to performing maintenance on pneumatic components.</p>

- Always inform the operator before performing maintenance operations and tag out the system.
- Secure the maintenance area with temporary barriers if needed.
- Clean the affected parts, especially the connections and fittings.
- If the dismantling of safety equipment is necessary, reinstall and inspect it immediately after completion of the maintenance work.
- Make sure to remove all tools and equipment after performing maintenance work to avoid ejecting or falling parts, material damage and bodily injury.
- Always verify fastener torque after performing maintenance work.
- Only use original spare parts.

6.2. Maintenance

The Vacuum Gripper only requires external maintenance with limited downtime.

Maintenance is required after specified usage, measured in cycles (workpiece pick-up and release) or use time (hours).

6.2.1. Cleaning of Suction Cups

Workspace conditions	Interval
Dirty	Daily
Normal	Monthly

Table 6-1: Cleaning Intervals for Suction Cups

- Clean the suction cups with warm water and soap. Remove all debris, dirt and dust from their surfaces.
- If applicable, clean the suction cups mesh filter using compressed air.
- If wear is visible, replace the suction cups. Please refer to the **Spare Parts, Kits and Accessories** section.



6.2.2. Periodic Inspection

Operation	Interval
Visual inspection of the electrical cables and fixtures for excessive wear	Monthly
Visual inspection of the pneumatic tubing and fixtures for excessive wear	Monthly
Visual inspection of suction cups for cracks or damage	Every six (6) months

Table 6-2: Periodic inspection intervals

- Visually inspect the PowerPick Vacuum Gripper and pay attention to any visible damage or wear. If necessary, contact support@robotiq.com.
- If wear is visible on the suction cups, replace them. See the **Spare Parts, Kits and Accessories** section. If grip reliability is reduced or the grip time is increased (boxes are regularly dropped or vacuum level takes more time to be obtained, even if the rest of the elements are in good condition), replace the cups.
- If an air tube is crushed or kinked, replace it.

6.2.3. Fasteners

Inspect the fasteners on a monthly basis to make sure that all the bolts are tightened.

If necessary, tighten the fasteners according to the torque values specified in the table below.

Designation	Location	Torque	
		Metric	Imperial
M6 x 1.0 Hex Socket Head Cap Screw with captive spring washer	Robot wrist	8 Nm	5.9 lb-ft
	Wrist extension	8 Nm	5.9 lb-ft
M6 x 1.0 Hex Socket Head Cap Screw, length 10 mm	Manifold	0.5 Nm	0.4 lb-ft
M6 x 1.0 Hex Socket Head Cap Screw, length 15 mm	Suction cup brackets	9.5 Nm	7.0 lb-ft

Table 6-3: Torque Settings for Fasteners on PowerPick10 Gripper



7. Spare Parts, Kits and Accessories

Item	Description	Ordering number
PowerPick10 Vacuum Gripper Standard Kit	<p>PowerPick10 Vacuum Gripper Standard Kit:</p> <ul style="list-style-type: none"> • 1 x PowerPick10 Vacuum Generation Unit <ul style="list-style-type: none"> • 1 x Vacuum Generator • 1 x Mounting bracket & Filter-regulator assembly • 1 x M12-12 pin I/O cable • 1 x Grommet and pneumatic fitting for installation on AX10 • 1 x Hardware for protective earth electrical connection • 1 x PowerPick10 Standard Gripper Unit <ul style="list-style-type: none"> • 1 x PowerPick10 Standard Vacuum Gripper, default configuration • 1 x PowerPick10 Offset Accessory Kit • 1 x 10 mm double air tube (3 m) • 1 x Tools and hardware for installation on UR10 	VAC-POWERPICK-KIT
PowerPick10 Vacuum Gripper Single Kit	<p>PowerPick10 Vacuum Gripper Kit:</p> <ul style="list-style-type: none"> • 1 x PowerPick10 Vacuum Generation Unit <ul style="list-style-type: none"> • 1 x Vacuum Generator • 1 x Mounting bracket & Filter-regulator assembly • 1 x M12-12 pin I/O cable • 1 x Grommet and pneumatic fitting for installation on AX10 • 1 x Hardware for protective earth electrical connection • 1 x PowerPick10 Single Cup Gripper Unit <ul style="list-style-type: none"> • 1 x PowerPick10 Single Cup Vacuum Gripper, default configuration • 1 x 10 mm double air tube (3 m) • 1 x 10 mm double air tube extension (5 m) 	VAC-POWERPICK10-SINGLE-KIT



	<ul style="list-style-type: none"> • 1 x Tools and hardware for installation on UR10 	
PowerPick10 Vacuum Gripper Single - No suction cup	<p>PowerPick10 Vacuum Gripper Kit:</p> <ul style="list-style-type: none"> • 1 x PowerPick10 Vacuum Generation Unit <ul style="list-style-type: none"> • 1 x Vacuum Generator • 1 x Mounting bracket & Filter-regulator assembly • 1 x M12-12 pin I/O cable • 1 x Grommet and pneumatic fitting for installation on AX10 • 1 x Hardware for protective earth electrical connection • 1 x PowerPick10 Single Cup Gripper Unit <ul style="list-style-type: none"> • 1 x PowerPick10 Single Cup Vacuum Gripper, without a suction cup • 1 x 10 mm double air tube (3 m) • 1 x 10 mm double air tube extension (5 m) • 1 x Tools and hardware for installation on UR10 	VAC-POWERPICK10-SINGLE-NO-CUP
PowerPick10 Vacuum Generation Unit	<p>PowerPick10 Vacuum Generation Unit: 1</p> <ul style="list-style-type: none"> • 1 x PowerPick10 Vacuum Generator • 1 x M12-12 pin I/O cable 	VAC-POWERPICK-CTRL-UNIT
PowerPick10 Gripper Unit	<p>PowerPick Standard Vacuum Gripper kit: 2</p> <ul style="list-style-type: none"> • 1 x PowerPick10 Standard Vacuum Gripper, default configuration <ul style="list-style-type: none"> • 1 x Manifold assembly • 1 x 200 mm horizontal offset tube • 2 x Small suction cup brackets • 4 x 75 mm suction cups • 2 x 8 mm air tubes (250 mm) • 2 x 8 mm air tubes (350 mm) • 1 x PowerPick10 Offset Accessory Kit <ul style="list-style-type: none"> • 2 x Large suction cup brackets • 4 x Additional 8 mm air tubes (400 mm) • 1 x 100 mm horizontal offset tube • 1 x 0 mm offset plate 	VAC-POWERPICK-GRP-UNIT



	<ul style="list-style-type: none"> • 1 x 120 mm wrist extension assembly • 1 x 10 mm double air tube (3 m) • 1 x Tools and hardware for installation on UR10 	
PowerPick10 Single Cup 100 mm Offset Kit	<p>PowerPick10 Single Cup Gripper 100 mm "X" Offset Kit: 3</p> <ul style="list-style-type: none"> • 1 x 100 mm Hollow Offset Link • 4 x M6 x 15 mm socket head cap screws • 2 x Strengthening brackets • 2 x 8 mm air tubes (300 mm) 	VAC-POWERPICK10-SINGLE-XOFF100
PowerPick10 Single Cup 200 mm Offset Kit	<p>PowerPick10 Single Cup Gripper 200 mm "X" Offset Kit:3</p> <ul style="list-style-type: none"> • 1 x 200 mm Hollow Offset Link • 4 x M6 x 15 mm socket head cap screws • 2 x Strengthening brackets • 2 x 8 mm air tubes (400 mm) 	VAC-POWERPICK10-SINGLE-XOFF200
PowerPick10 Single Cup Wrist Extension Kit	<p>PowerPick10 Single Cup Gripper "Z" Offset Kit:3</p> <ul style="list-style-type: none"> • 1 x 120 mm Wrist Extension • 4 x M6 x 15 mm socket head cap screws with captive spring washer • 2 x 8 mm air tubes (200 mm) 	VAC-POWERPICK10-SINGLE-ZOFFSET
52 mm suction cups	<p>Kit of 4 suction cups:</p> <ul style="list-style-type: none"> • 4x Piab 52 mm (1.5 bellows) with 3/8-19 BSPP thread 	VAC-CUP-PIAB-52MM-G38-KIT-4
	<ul style="list-style-type: none"> • 1 x Piab 52 mm (1.5 bellows) with 3/8-19 BSPP thread 	VAC-CUP-PIAB-52MM-G38-1
75 mm suction cups	<p>Kit of 4 suction cups:</p> <ul style="list-style-type: none"> • 4 x Piab 75 mm (1.5 bellows) • 4 x 3/8-19 BSPP threaded adapters 	VAC-CUP-PIAB-75MM-G38-KIT-4
	<ul style="list-style-type: none"> • 1 x Piab 75 mm (1.5 bellows) • 1 x 3/8-19 BSPP threaded adapters 	VAC-CUP-PIAB-75MM-G38-1
78 mm suction cups	<p>Kit of 4 suction cups:</p> <ul style="list-style-type: none"> • 4 x Coval 78 mm (1.5 bellows) 	VAC-CUP-COVAL-78MM-G38-KIT-4



	<ul style="list-style-type: none"> • 4 x 3/8-19 BSPP threaded adapters 	
90 mm suction cups	<ul style="list-style-type: none"> • 1 x Piab 90 mm (1.5 bellows) • 1 x 3/8-19 BSPP threaded adapters 	VAC-CUP-PIAB-90MM-G38-1

1 This SKU does not include the PowerPick10 Standard Gripper Unit or the mounting bracket & filter-regulator assembly.

2 This SKU does not include the PowerPick10 Vacuum Generation Unit.

3 This SKU does not include the PowerPick10 Single Cup Gripper Unit.

Table 7-1: PowerPick10 Spare Parts, Kits and Accessories



8. Troubleshooting

Symptom / Issue	Cause	Solution
The boxes are not picked or dropped reliably	The vacuum level at the suction cups is not at the right level.	Validate that the PowerPick10 Vacuum Generator input pressure is at the right level. If needed, increase it to 7 bar (100 psi).
		Verify that the suction cups are in good condition. If needed, clean them (please refer to the Maintenance section). If wear is visible, replace them (please refer to the Spare Parts, Kits and Accessories section).
		Verify that there is no air leak in the circuit between the PowerPick10 Vacuum Generator and the suction cups.
		Verify that the air path, manifold and suction cups mesh filter are clean and not obstructed.
Nothing happens when the vacuum and/or blowoff is activated	There must be an electrical or pneumatic issue	Make sure the wires are correctly connected (please refer to the Electrical Installation section).
		Verify that the feed air pressure is at least 3 bar (43.5 psi)



Table 8-1: PowerPick10 Troubleshooting Guidelines



9. Warranty

9.1. Conditions

Robotiq warrants the PowerPick10 and all its components against defects in material and workmanship for a period of one (1) year from the date of reception when utilized as intended. Robotiq also warrants that this equipment will meet applicable specifications under normal use.

	 WARNING
	<p>The warranty applies under the following conditions:</p> <ul style="list-style-type: none"> • Usage is made in accordance with the operating and storage conditions specified in the Environmental and Operating Conditions section. • The product and all its components have been properly installed as specified in the Installation section and following subsections. • Maintenance is performed in accordance with the conditions specified in the Maintenance section. • Usage complies with the recommended payload, air pressure and acceleration values specified in the Specifications section. <p>The warranty will come to an end when one of the following conditions is reached, whichever comes first:</p> <ul style="list-style-type: none"> • One (1) year • 2,000,000 opening and closing cycle counts for each valve. Once one of the valves reaches the count, the warranty will not apply anymore.

	NOTICE
	<p>Cycle count definition: One (1) cycle count is defined as the activation of the component, which in this case is creating and releasing the vacuum.</p>

During the warranty period, Robotiq will repair or replace any defective PowerPick10 and any of its components, as well as verify and adjust the equipment free of charge if it needs to be repaired or if the original adjustment is erroneous. If the equipment is sent back for verification during the warranty period and found to meet all pertaining specifications, Robotiq will charge standard verification fees. If the PowerPick10 feedback necessary for the robot program is not accessible, the unit is considered defective.



9.2. Warranty Void and Exclusions

The warranty will become void if:

- The unit has been tampered with, repaired or worked on by unauthorized individuals.
- The screws and hardware, other than as explained in this guide, have been removed.
- The unit has been opened other than as explained in this guide.
- The unit serial number has been altered, erased, or removed.
- The unit has been misused, neglected, or damaged.
- The Vacuum Generator has been opened by anyone other than a Robotiq employee.

This warranty is in lieu of all other expressed, implied, or statutory warranties, including, but not limited to, the implied warranties of merchantability and fitness for a particular purpose.

Robotiq shall not be liable for damages resulting from the use of the PowerPick10, nor from special, incidental, or consequential damages. Robotiq shall also not be responsible for any failure in the performance of other items to which the PowerPick and any of its components is connected or the operation of any system of which it may be a part.

This warranty excludes failure resulting from: improper use or installation, normal wear and tear, accident, abuse, neglect, fire, water, lightning or other acts of nature, causes external to the PowerPick10 and any of its components or other factors beyond Robotiq's control. It also excludes all consumable parts, such as suction cups, and their normal wear.

Robotiq reserves the right to make changes in the design or construction of any of its products at any time without incurring any obligation to make any changes whatsoever on units already purchased.



10. Harmonized Standards

The standards listed in the table below were followed, as far as applicable, for the design and production of the Robotiq PowerPick10 Vacuum Gripper.

Standard	Year	Description
ISO 12100	2010	Safety of machinery — General principles for design — Risk assessment and risk reduction
ISO 9409-1	2004	Manipulating industrial robots – Mechanical interfaces – Part 1: Plates
ISO 4414	2010	Pneumatic fluid power – General rules and safety requirements for systems and their components
IEC 61000-6-2	2016	Generic standards – Immunity standard for industrial environments
IEC 61000-6-4	2018	Generic standards – Emission standard for industrial environments

Table 10-1: PowerPick10 Applicable Standards



11. Appendix

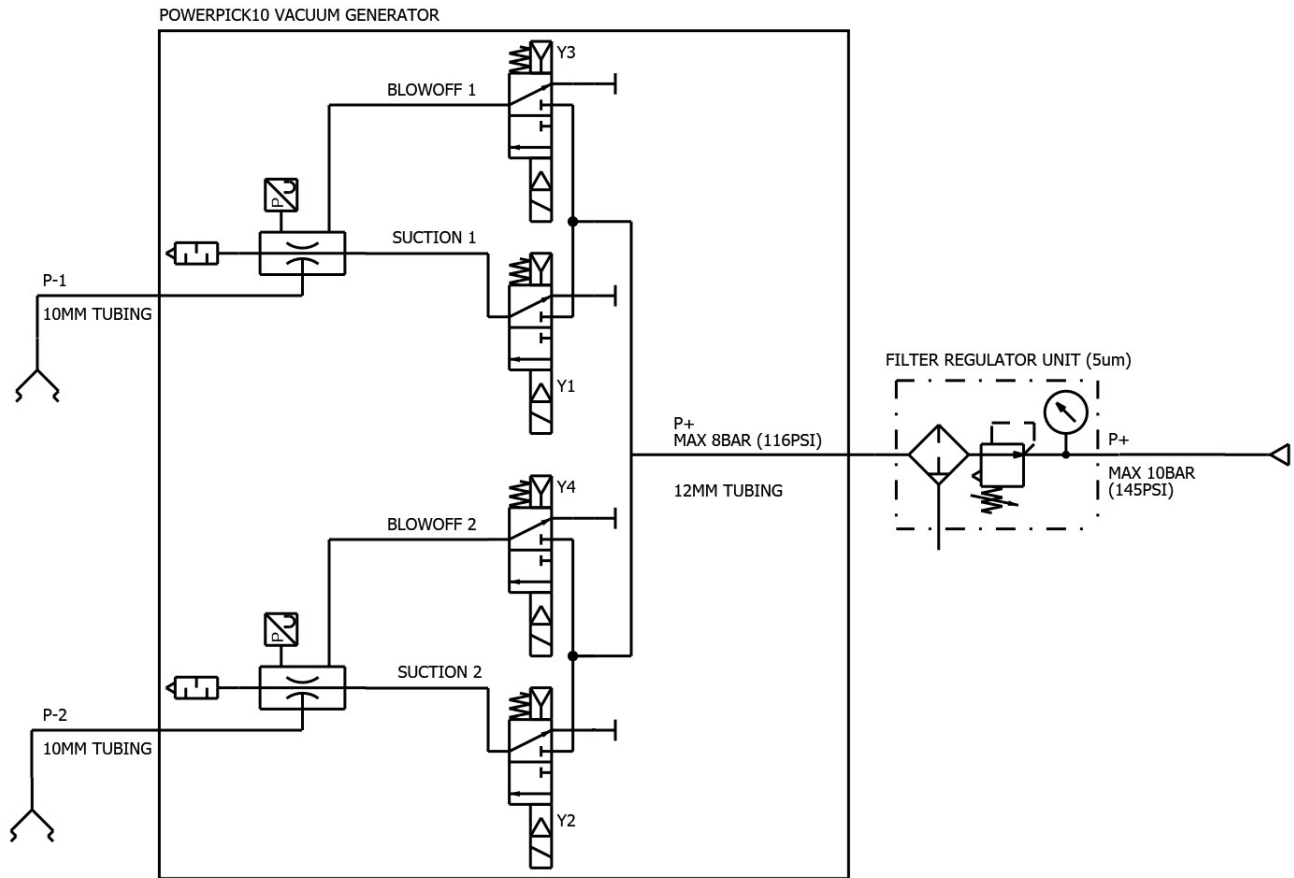

Fig. 11-1: Pneumatic Diagram of PowerPick10 with Filter-Regulator Unit



12. Contact

www.robotiq.com

Contact Us

Phone

1-888-ROBOTIQ (762-6847)
(01) 418-380-2788 Outside US and Canada

Technical support and engineering

option 3

Sales

option 2

Head office

Robotiq:
966, chemin Olivier
Suite 500
Lévis, Québec
G7A 2N1
Canada

