

THANK YOU FOR CHOOSING ROBOTIQ

This Quick Start Guide will help you install and use your **Sanding Kit** with Universal Robots.



1. WHAT IS SUPPLIED?

AIR RANDOM ORBITAL SANDER AND MOUNTING KIT.....(SAND-ROS-001)

- Dynabrade sander Model: 56819B
- 5 sanding pads (grits 80, 120, 220, 320, 400)
- Adapter plate
- Holding plate

AIR CONTROL ACCESSORIES.....(ACC-AIR-001)

- Control valve
- 3/8 inch air tube
- Magnetic holding plate

COPILOT LICENCE DONGLE..... (W-A05-A)



2. REQUIRED TOOLS

- 11/16 inch wrench (not included)
- 4mm hex key (included)
- 3mm hex key (included)

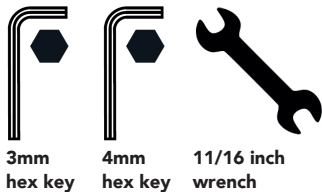

3mm hex key 4mm hex key 11/16 inch wrench



3. GET THE LATEST SOFTWARE

1. Visit support.robotiq.com.
2. Download the latest User Manual for your product (PDF or HTML).
3. Download the latest **.urcap** package for your product, decompress the ZIP file and copy the **.urcap** file to a USB stick.



4. MOUNTING

ASSEMBLING THE SANDER

1. Remove the orange cap covering the compressed air inlet of the sander.
2. Screw the provided 1/4 inch NPT air fitting into the sander air inlet. Tighten using a 11/16 inch wrench.

i Move the robot wrist to make it point upwards. This will facilitate mounting your product.

MOUNTING THE SANDER ON THE ROBOT WRIST

1. Secure the adapter plate on the robot wrist with four M6 screws, using a 4mm hex key. Align using dowel pin.
2. Insert the sander into the adapter plate, and insert one M3 screw into the hinge, using a 3mm hex key.
3. Secure the holding plate over the adapter plate with three M4 screws, using a 3mm hex key.
4. Press the sanding soft interface disc pad to the sander.
5. Select a sanding media, and gently press it (grit side up) into the sanding soft interface disc pad.
6. Tighten the adapter plate set screw until you feel some resistance, using a 3mm hex key. The screw allows turning on the sander.

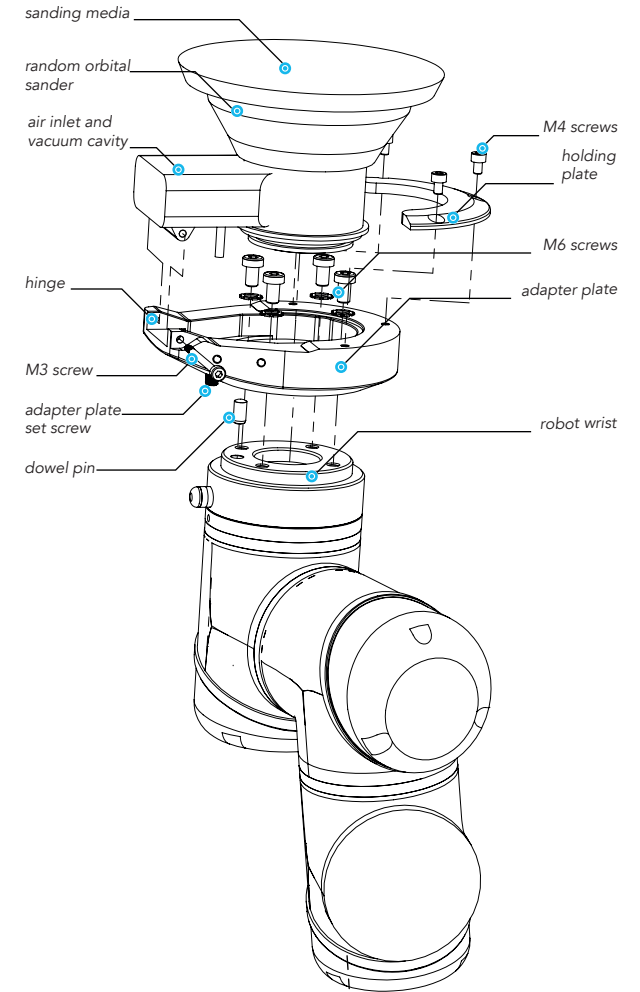

Figure 1. Sanding Kit exploded view, on robot arm.



BEFORE OPERATING THIS DEVICE, PLEASE READ ITS INSTRUCTION MANUAL.



4. MOUNTING (continued)

SUPPLYING AIR TO THE VALVE

For more details, see Figure 2.

1. Push the 3/8 inch air tube into the sander air inlet fitting.
2. Push the 3/8 inch air tube into Port #2 of the valve.
3. Screw in a 1/4 inch NPT air fitting in Port #1 of the valve.

i The 1/4 inch NPT air fitting for Port #1 is not included. Insert your own air fitting based on your air line specifications.

4. Connect your air supply line to Port #1.

i To change the rotation speed of your random orbital sander, turn the knob found under the air inlet, on the sander.

5. Secure the valve to the cabinet using the valve magnetic clip.



STRONG MAGNETS. HOLD VALVE BRACKET FIRMLY WHEN ATTACHING IT TO A SURFACE TO AVOID DAMAGING MAGNETS.

CONNECTING A CENTRAL VACUUM SYSTEM (OPTIONAL)

To connect your central vacuum system to the sander, plug it into the 7/8 inch round socket found under the air inlet of the sander.

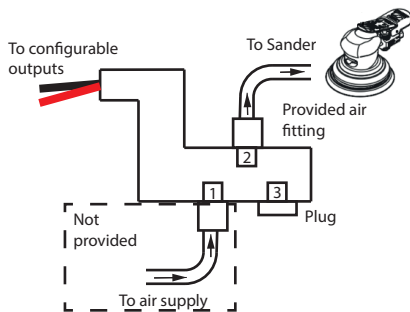

Figure 2. Supplying air to your valve.





5. WIRING

1. Turn off your robot controller.
2. Plug the black wire of the valve into a **0V** connector of the robot controller.
3. Plug the red wire of the valve into a **Configurable Output**.



6. SOFTWARE INSTALLATION

1. Insert your Copilot licence dongle into a USB port of your robot controller.
2. Insert a USB stick loaded with the **.urcap** into the Teach pendant.
3. Tap the triple bar icon  in the upper right corner, select **Settings**, then **System** from the left navigation pane.
4. Tap **URCaps** in the pane, then  at the bottom of the screen, and select the USB stick loaded with the **.urcap**.
5. **Open** the file **Robotiq_Copilot-X.X.X.urcap**.
6. To activate the URcap, tap **Restart** in the bottom right corner of the screen.

i To access features available to the Finishing Copilot software and essential to your sanding applications, the USB licence dongle must remain plugged in a USB port of the robot controller.



Sanding Kit

QUICK START GUIDE

For installation on Universal Robots



support.robotiq.com

support@robotiq.com
T: 1.418.380.2788 ext. 3

June 2019
V1.0